

Condensing boiler technology

ebmpapst

The engineer's choice

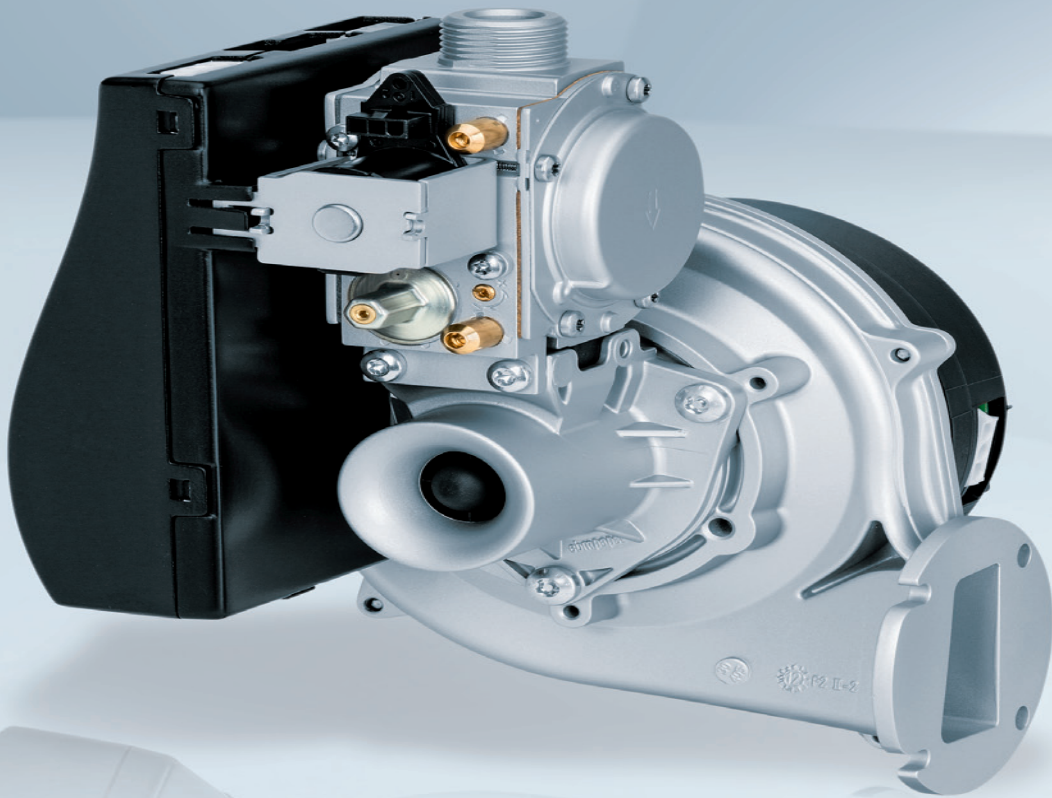

По вопросам продаж и поддержки обращайтесь:

Архангельск (8182)63-90-72	Калининград (4012)72-03-81	Нижний Новгород (831)429-08-12	Смоленск (4812)29-41-54
Астана +7(7172)727-132	Калуга (4842)92-23-67	Новокузнецк (3843)20-46-81	Сочи (862)225-72-31
Белгород (4722)40-23-64	Кемерово (3842)65-04-62	Новосибирск (383)227-86-73	Ставрополь (8652)20-65-13
Брянск (4832)59-03-52	Киров (8332)68-02-04	Орел (4862)44-53-42	Тверь (4822)63-31-35
Владивосток (423)249-28-31	Краснодар (861)203-40-90	Оренбург (3532)37-68-04	Томск (3822)98-41-53
Волгоград (844)278-03-48	Красноярск (391)204-63-61	Пенза (8412)22-31-16	Тула (4872)74-02-29
Вологда (8172)26-41-59	Курск (4712)77-13-04	Пермь (342)205-81-47	Тюмень (3452)66-21-18
Воронеж (473)204-51-73	Липецк (4742)52-20-81	Ростов-на-Дону (863)308-18-15	Ульяновск (8422)24-23-59
Екатеринбург (343)384-55-89	Магнитогорск (3519)55-03-13	Рязань (4912)46-61-64	Уфа (347)229-48-12
Иваново (4932)77-34-06	Москва (495)268-04-70	Самара (846)206-03-16	Челябинск (351)202-03-61
Ижевск (3412)26-03-58	Мурманск (8152)59-64-93	Санкт-Петербург (812)309-46-40	Череповец (8202)49-02-64
Казань (843)206-01-48	Набережные Челны (8552)20-53-41	Саратов (845)249-38-78	Ярославль (4852)69-52-93

сайт: www.ebmpapstnt-rt.ru || эл. почта: etm@nt-rt.ru





About ebm-papst	4
Laboratory equipment	8
Systems for condensing boiler technology	10
Radial blowers	16
Gas valves	34
Burner controls	42
ebm-papst representatives & subsidiaries	48

ebm-papst Landshut is the ideal partner for developing heating units.



ebm papst Landshut is THE ideal partner for developing heating systems.

Condensing boiler technology has been advancing steadily since the 1990s. ebm-papst Landshut has been the top supplier for premix blowers for just as long. We were there from the start. We developed and supplied the world's first blower for condensing boiler technology. However, we also developed ourselves, evolving from the largest supplier of premix blowers to a developer of complete systems for condensing boiler technology consisting of a blower, venturi, valve and burner control. That, too, remains unmatched anywhere in the world.

Sustainability is at the centre of our thoughts and actions. Out of conviction!

Eco-friendliness and sustainability have always been at the core of our thoughts and actions. For decades, we have worked according to the simple but strict creed of our co-founder Gerhard Sturm: "Each new product we develop has to be better than the last one in terms of economy and ecology." GreenTech is the ultimate expression of our corporate philosophy.

GreenTech is pro-active development.

Even in the design phase, the materials and processes we use are optimised for the greatest possible eco-friendliness, energy balance and – wherever possible – recyclability. We continually improve the material and performance of our products, as well as the flow and noise characteristics. At the same time, we significantly reduce energy consumption. Close co-operation with universities and scientific institutes and the professorship we endow in the area of power engineering and regenerative energies allows us to profit from the latest research findings in these fields – and at the same time ensures highly qualified young academics.

GreenTech is eco-friendly production.

GreenTech also stands for maximum energy efficiency in our production processes. There, the intelligent use of industrial waste heat and groundwater cooling, photovoltaics and, of course, our own cooling and ventilation technology are of the utmost importance. Our most modern plant, for instance, consumes 91% less energy than currently specified and required. In this way, our products contribute to protecting the environment, from their origin to their recyclable packaging.

GreenTech is acknowledged and certified.

Every step in our chain of production meets the stringent standards of environmental specialists and the public. This supports our position as Germany's most sustainable company 2013, as does the DEKRA Award 2012 we received in the category "Umwelt – Herausforderung Energiewende / Environment – Challenge: Transition to more sustainable energy systems", to name only a few of a large number of examples. The environmental advantage gained in the performance of the products developed from our GreenTech philosophy can also be measured in the fulfillment of the most stringent energy and environmental standards. In many instances, our products are already well below the thresholds energy legislation will impose a few years from now – several times over.

Our customers profit from this every day.

The heart of GreenTech is future-oriented EC technology from ebmpapst. The EC technology at the core of our most efficient motors and fans allows efficiency of up to 90%, saves energy at a very high level, significantly extends service life and makes our products maintenance-free. These values pay off not only for the environment, but every cent also pays off for the user! All ebmpapst products – even those for which GreenTech EC technology does not (yet) make sense from an application viewpoint – feature the greatest possible connection of economy and ecology.

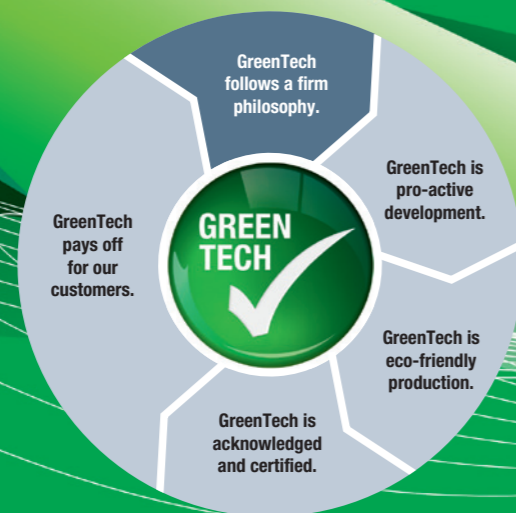

GreenTech means
ecologically improving
every new product.

Laboratory equipment



We have the research and development expertise needed for continuous improvement in today's world: Dedicated, intelligent engineers and technicians who work to further develop products, co-operating with our customers' development teams. The range of analyses is not limited to harmful emissions. We also analyse and optimise EMC and noise emissions.

We support our customers in the development of applications from the very beginning. Only when all of the necessary characteristics are present does the product go into production. The tests required for this purpose include both inspections for complying with legal mandates and specific customer requirements. Numerous measuring devices are available directly at the Landshut location for this purpose.

For example, we also test for design effects, such as changes to the gas-air manifold, check valves or the venturi. All of these factors can influence the efficiency – as well as the noise level and function – of a condensing boiler and must be taken into account when matching the individual components to each other.

Gas laboratory

ebm-papst Landshut has a gas laboratory with state-of-the-art measuring devices. The laboratory can also take into account country-specific differences, as each country has its own legislation for the composition of the gases and the minimum and maximum supply pressure. The inlet pressure in the supply line can be varied to show the effects of various supply networks. In addition, all testing and limit gases commonly used in Europe, America and Asia are available.

We carry out exhaust gas measurements (CO_2 , CO, lambda) and measurements with variable aerodynamic parameters (venturi pressure, modulation range, mass flow). The climate chamber also allows both short-term and endurance testing of external variables such as temperature and humidity. Wind and turbulence at the air-intake area can also be simulated. The volume of condensate produced by the condensing effect can be determined to measure the efficiency of the system.

Air performance test rig

Multiple air performance test rigs are available. They test the operating performance of the blowers and plot the air performance curves.

Spectrum analyser

The spectrum analyser can be used to measure line-bound interference. Since our devices are used for further processing in expert industrial companies, we are not actually required to test their electromagnetic compatibility (EMC measurement). Nevertheless, we would like to offer this service to our customers. This tests whether the motors fulfill the requirements of EN-55014-1, thus ensuring that there is no interference with devices in the environment.

Climate chamber

Multiple climate chambers are available in various sizes. They enable endurance tests to be carried out in a variety of ambient conditions (temperature, humidity, air pressure). This also makes it possible to determine the service life of the devices.

Noise measurement laboratory

The noise behaviour of our blowers and systems is tested in our soundproof noise measurement laboratory featuring state-of-the-art, high-precision sound measuring systems. By the way, these are the same real-world conditions in which they are built into our customers' products.

Additional equipment

Our equipment also includes a high-resolution 3D microscope and a 3D plotter for rapid prototyping, which can be used to fabricate plastic parts for tests on short notice.

We can also carry out vibration tests to simulate mechanical loads, such as those that occur during transport of the blowers. Equipment for testing the type of protection is also available. They allow ambient influences to be tested based on DIN EN 60529.

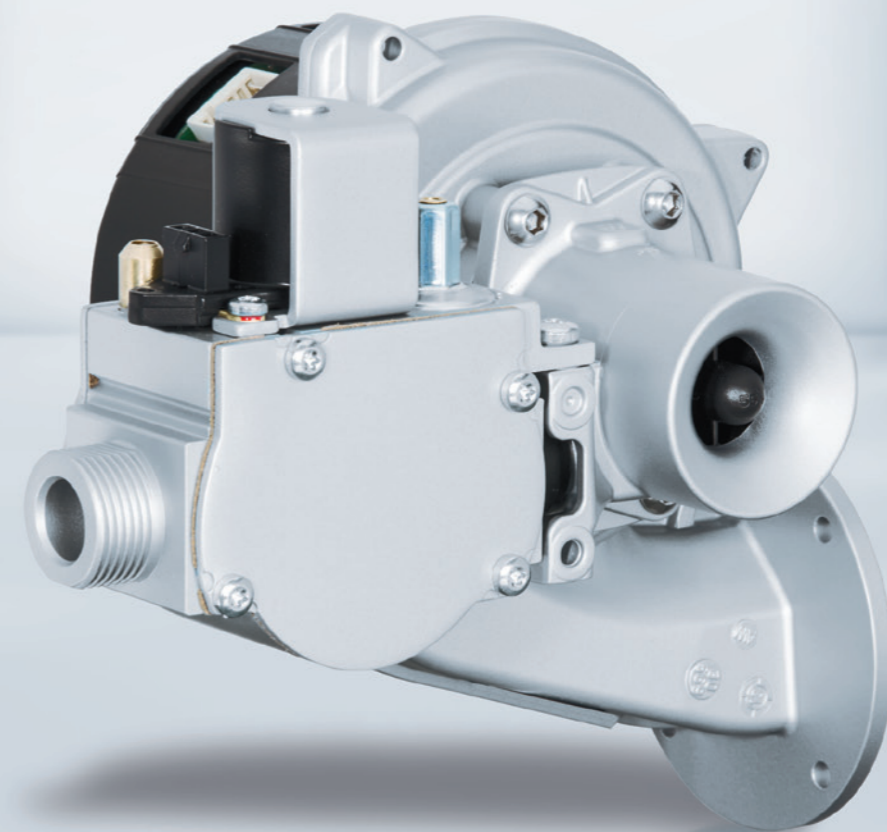

Systems for condensing boiler technology

Condensing boiler versus conventional heating.

The difference is that in condensing boiler systems, the water vapour present in the exhaust is condensed before exiting the flue and is used to extract additional heat. Relative to conventional heating systems, which do not use this effect, this allows a significantly higher efficiency of up to 111% to be attained relative to the lower heating value.

In times of increasingly scarce raw materials, existing energy sources have to be used as efficiently as possible. Therefore, it is important to replace the old conventional heating units with high-efficiency condensing boiler systems.

Design of a condensing boiler heating unit.

What can we supply you with? And what do you get out of it?

Venturi

The pressure generated by the venturi effect provides an optimum mixture of gas and air in the pneumatic gas-air ratio control.

Gas blower

State-of-the-art blower technology for modulating operation with low noise and a long service life.

Gas valve

The part required for the correct gas quantity has a particularly compact design.

Burner control with display

In co-operation with ebmpapst Heating Systems, the electronic control is matched precisely to the system. Signals from the burner controls can be read out in the lab using LabVision software.

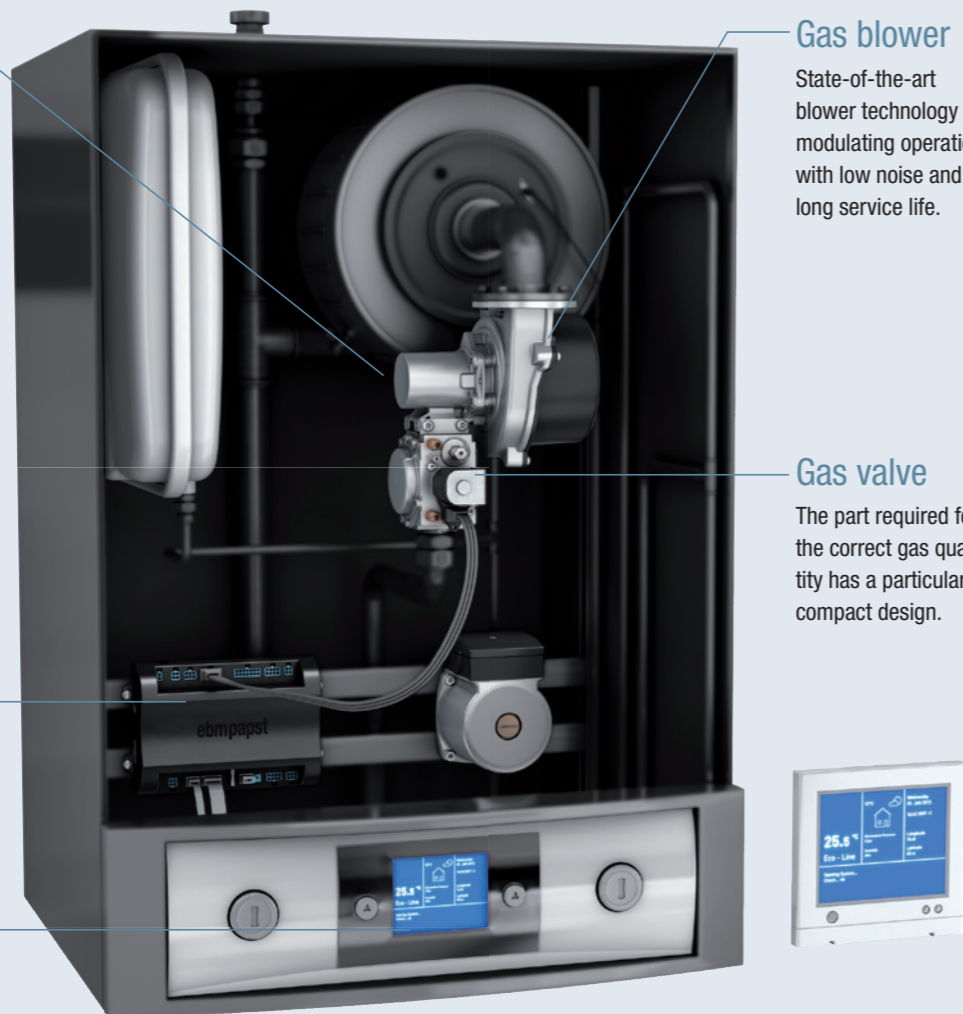

Perfectly matched components of a condensing boiler.

The mixture ratio of gas to air is critical for the energy yield during combustion. If the gas content is too high, we refer to the mixture as being too rich. Since there is not enough oxygen available, the gas is not completely burned off and it is dissipated with the exhaust gas.

This not only wastes a lot of energy, the exhaust gases also contain undesirable products such as carbon monoxide (CO) and carbon particulate matter. The opposite situation – when the gas content is too low – can, in extreme cases, cause the flame in the burner to go out. Therefore, having the correct mixture is of critical importance. This is attained only if the system is optimally matched for premixing gas and air or oxygen. This is not so easy in practice. Just one example of a problem is the different gas qualities. Natural gas has a high methane content and thus a lower gross calorific value than liquid gas, which consists primarily of propane and butane mixtures. Bio-gas is also being used more and more frequently. The mixture ratio must be adjusted exactly to the gross calorific value of the different gas families – as must the air pressure and the temperature of the intake air and the supply pressure in the gas line.

Another challenge is the flexibility of the heat output. The greater the modulation range of a heating system, the better the heat output can be adjusted to the current demand. The limits of the modulation degree are determined by the minimum and maximum output of the premix blower. Even at a low heat output, the system has to have the ability to set the optimum mixture ratio. For this purpose, the components – blower, venturi, valve and burner control – have to be ideally matched to each other.

If these components are purchased from different manufacturers, configuring the interfaces and the operating performance optimally is an arduous task. Therefore, it is only logical for us to supply all four components as a finished system for premixing from a single source. This enables our customers to focus entirely on their core skills.

The following illustration shows the function of these components.

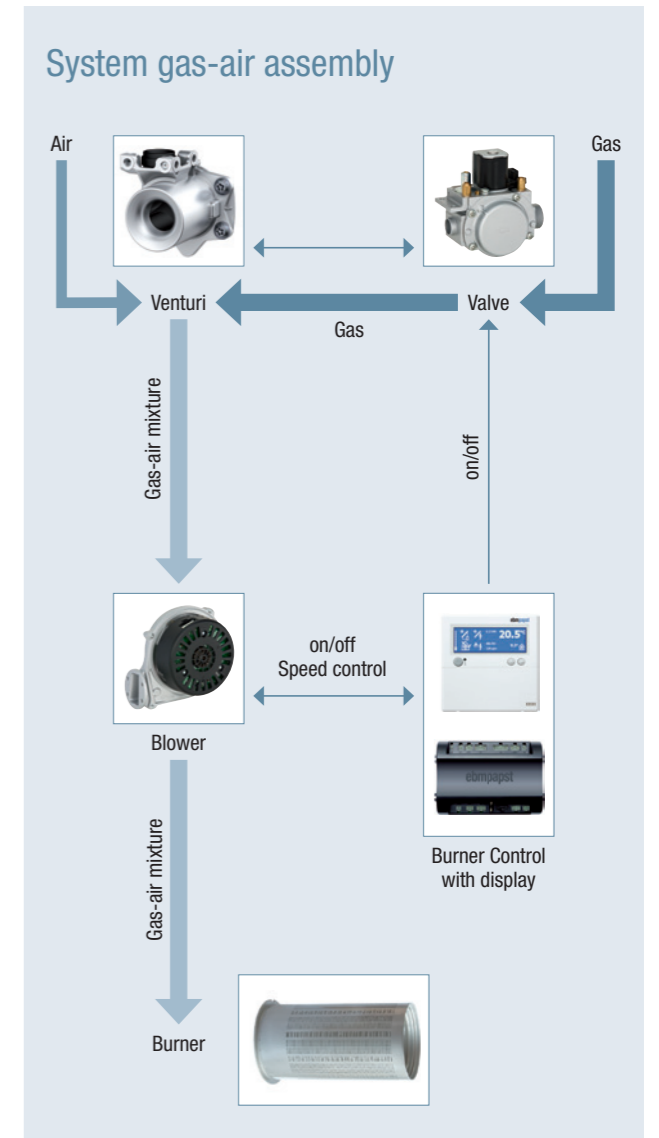

Figure 1: Schematic design of a system

Systems at a glance

Our system solutions at a glance

In heating engineering, it is essential that all components are perfectly co-ordinated in order to attain optimum output and efficiency. Therefore, we offer you complete heating systems from a single source, including gas blower, venturi and gas valve.

A substantial advantage of our venturi tubes is their optimum mixture ratio with simultaneously high modulation ranges. To achieve this high efficiency, we offer a variety of venturi inserts for the multi-venturi tubes tailored to specific heating capacity ranges. In addition, solutions with a multi-venturi offer a wide variety of options for arranging our systems in your devices. This gives you the advantage of

having the most flexible and space-saving integration possible.

For potential mounting positions, please refer to page 18. For additional potential attachment positions for a valve or specific attachments for air conduction, please contact us.

A burner control perfectly matched to the system is also possible thanks to our system partnership with ebm-papst Heating Systems, the Netherlands-based specialist for intelligent control technology. This can be mounted directly on the system or remotely.

We supply our systems as completely tested and fine-tuned units with optimised interfaces to save you time and money.

NRV 77 The system for heat outputs from 2 to 35 kW

Consisting of:

- Gas blower NRG 77 with multi-venturi
- Gas valve GB-ND 055 E01

	Heating range [kW]	Part number
Venturi 1	2–15	55734.33000
Venturi 2	5–28	55734.33010
Venturi 3	7–35	55734.33020

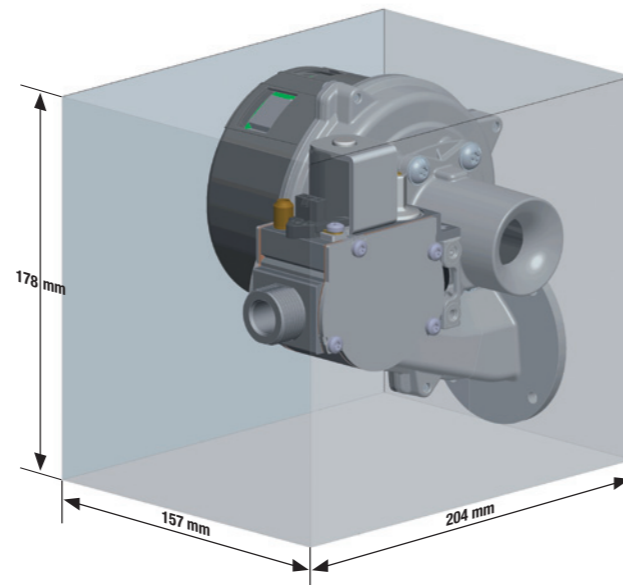

Sample on request.

NRV 118 The system for heat outputs from 3 to 42 kW

Consisting of:

- Gas blower NRG 118 with multi-venturi
- Gas valve GB-ND 055 E01

	Heating range [kW]	Part number
Venturi 1	3–23	55734.32010
Venturi 2	5–28	55734.32020
Venturi 3	7–42	55734.32030

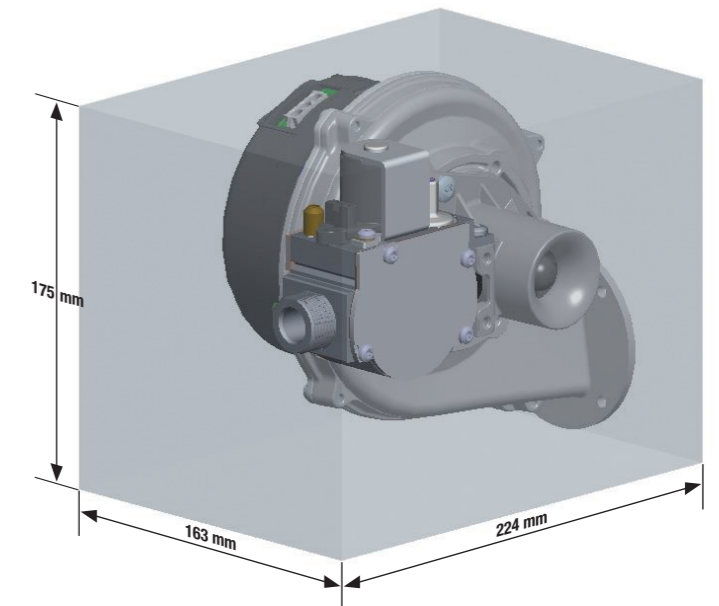

Sample on request.

NRV 137 The system for heat outputs from 15 to 145 kW

Consisting of:

- Gas blower NRG 137 with multi-venturi
- Gas valve GB-ND 057 D01

	Heating range [kW]	Part number
Venturi 1	15–90	55724.10000
Venturi 2	24–145	55724.10010

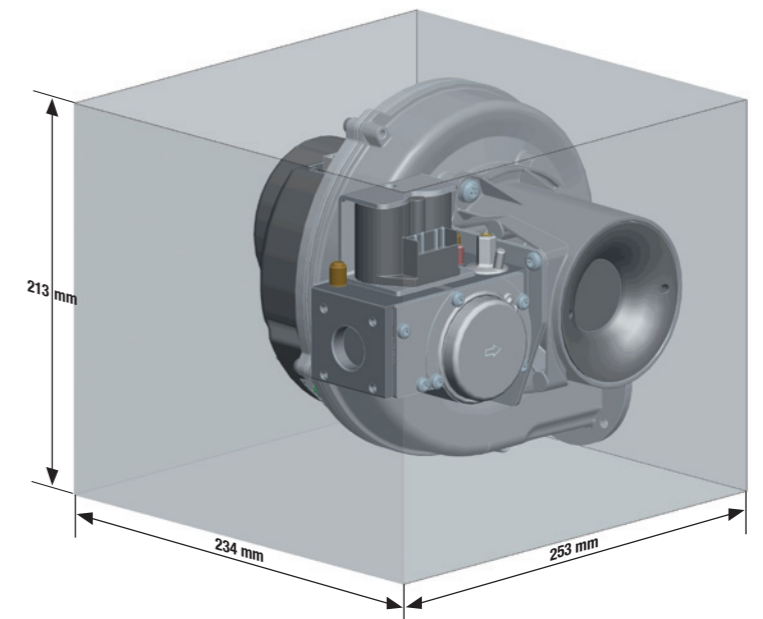

Sample on request.



Modern gas-fired or oil-fired modulating condensing boilers have to be supplied with the ideal volume and composition of air and fuel, whatever the operating state and external conditions. Controllable blowers with a steep pressure-flow rate curve and a high pressure maximum are required for this purpose. ebm-papst played a critical role in the development of suitable EC blowers for this and now offers the most extensive product line for this application area. The special properties of these blowers can, however, be used for many other applications as well. Some examples of this include gas-powered cookers in the food service industry and gas-powered deep fryers for commercial use.

Basic structure

Housing

The housing of NRG, RG and G1G/G3G blower types are made of die-cast aluminium, the housing of the HRG 134 is made of PA6 GF plastic. The tight sealing required for gas-premix technology is achieved by a special seal for the housing halves and the drive shaft entry point. The special requirements, inspections and approval criteria are co-ordinated for each individual case. The required safety inspections for the complete functional unit have to be carried out by the manufacturer of the terminal device.

Impellers

The impellers of HRG, NRG and RG blower types consist of pentane-resistant plastic. They are dynamically fine-balanced. Models G1G 170, G3G 200 and G3G 250 have impellers made of aluminium sheet.

Drive

The drive consists of brushless direct current (EC) motors with integrated electronics. The motor has a vibration-free mounting to minimise structure-borne noise.

Type of protection

The blowers fulfill the IP20 type of protection with cover, depending on the mounting position.

Protection class

The motors fulfill the requirements for protection class I.

Bearings

Maintenance-free ball bearings covered on both sides provide for durability and running smoothness.

Mounting positions



Mounting positions 1 to 5 are possible in general. For vibration-cushioned motor installation, the motor weight is also supported by an elastic element. Therefore, the mounting position must be specified. Consultation is required in conjunction with our systems and for mounting position 6.

Venturi tubes

Venturi tubes provide for the correct ratio of air flow to gas flow. In addition to this, the venturi's efficiency determines the maximum possible modulation degree of the heating system.

Here you see the possible rotation between venturi and blower – the gas valve is also pictured for clarification:



Potential mounting positions for the multi-venturi

You can obtain further details on the available venturi variants from your contact person on-site.

Commutation electronics

The motor electronics are integrated into the blower unit. This ensures that the commutation electronics are optimally tuned to the motor. Shutoff of rotor locking and overload protection are options that can be integrated. In individual cases, adaptation to the burner control is required.

Speed output

The blowers with the designation HRG, NRG and RG have a Hall IC signal output with two pulses per revolution. The G3G 250 MW has five pulses per revolution, while the G1G and G3G each have three pulses per revolution. In the case of motors for mains voltage operation, the speed signal output is galvanically isolated.

Speed control

The speed is controlled by a pulse-width modulated signal (PWM). You can obtain more information from your contact person on-site.

ErP 2015

ebm-papst fans with GreenTech EC technology meet the legal requirements for ErP directive Step 2 (by 2015). This directive applies to devices with an output greater than 125W. This catalogue provides information on blowers NRG 137, RG 148, RG 175, G1G and G3G.



Our comprehensive product portfolio offers blowers for heat output values from 2kW to 1MW. The overview shows the available blower types and the application area that we recommend. Please note that the heat output actually attained in the end device depends on various factors.

The gas type, burner and heat exchanger are just a few of the components responsible for achieving a certain output.

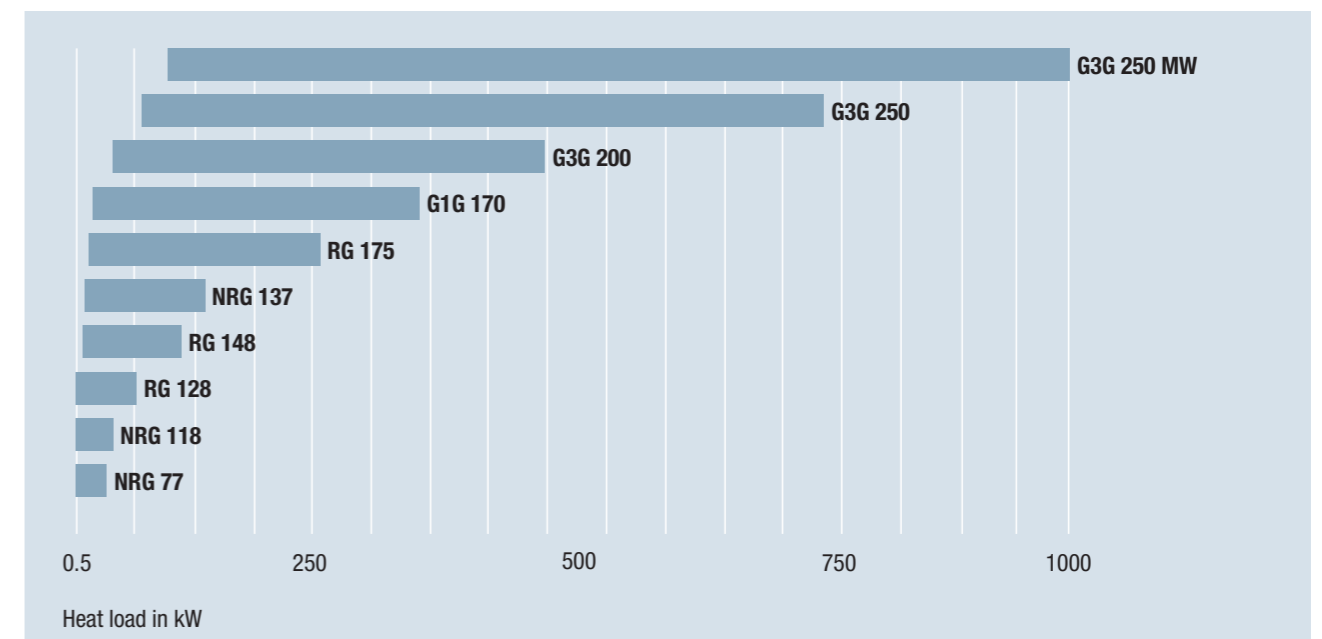

NRG 77



- **Material:** Housing: Aluminium
Impeller: Plastic
Motor protection cap: Plastic
- **For potential mounting positions, page 18**
- **Multi-venturi available**
- **Mains connector X, interface connector W and interface see page 31 ff.**



NRG 118

- **Material:** Housing: Aluminium
Impeller: Plastic
Motor protection cap: Plastic
- **For potential mounting positions, page 18**
- **Multi-venturi available**
- **Mains connector X, interface connector W and interface see page 31 ff.**

Nominal data	Rated voltage	Frequency	Max. air flow	Max. pressure increase	Max. input power	Max. speed	Perm. amb. motor temp.	Perm. temp. of medium	Part number
Type	V	Hz	m³/h	Pa	W	min⁻¹	°C	°C	
NRG 77	230	50/60	78	1650	50	12500	60	80	55667.70030

Subject to alterations.

Nominal data	Rated voltage	Frequency	Max. air flow	Max. pressure increase	Max. input power	Max. speed	Perm. amb. motor temp.	Perm. temp. of medium	Part number
Type	V	Hz	m³/h	Pa	W	min⁻¹	°C	°C	
NRG 118	230	50/60	95	2500	75	8500	60	80	55667.31160

Subject to alterations.

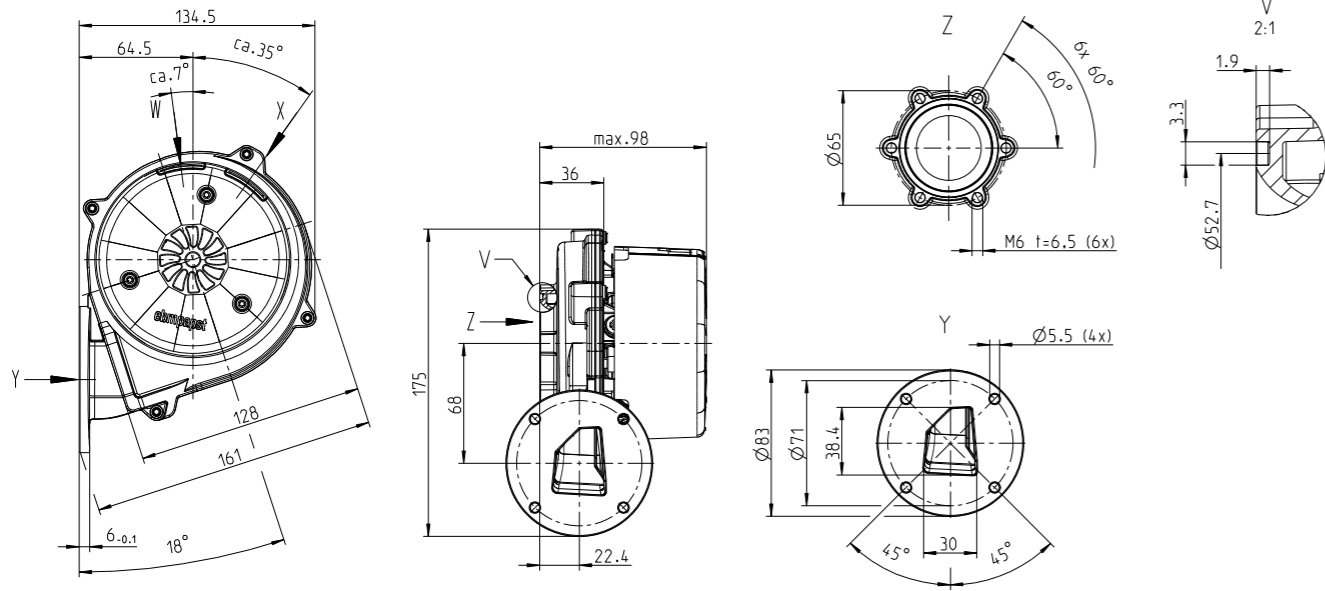

Dimensions in mm.

Curves

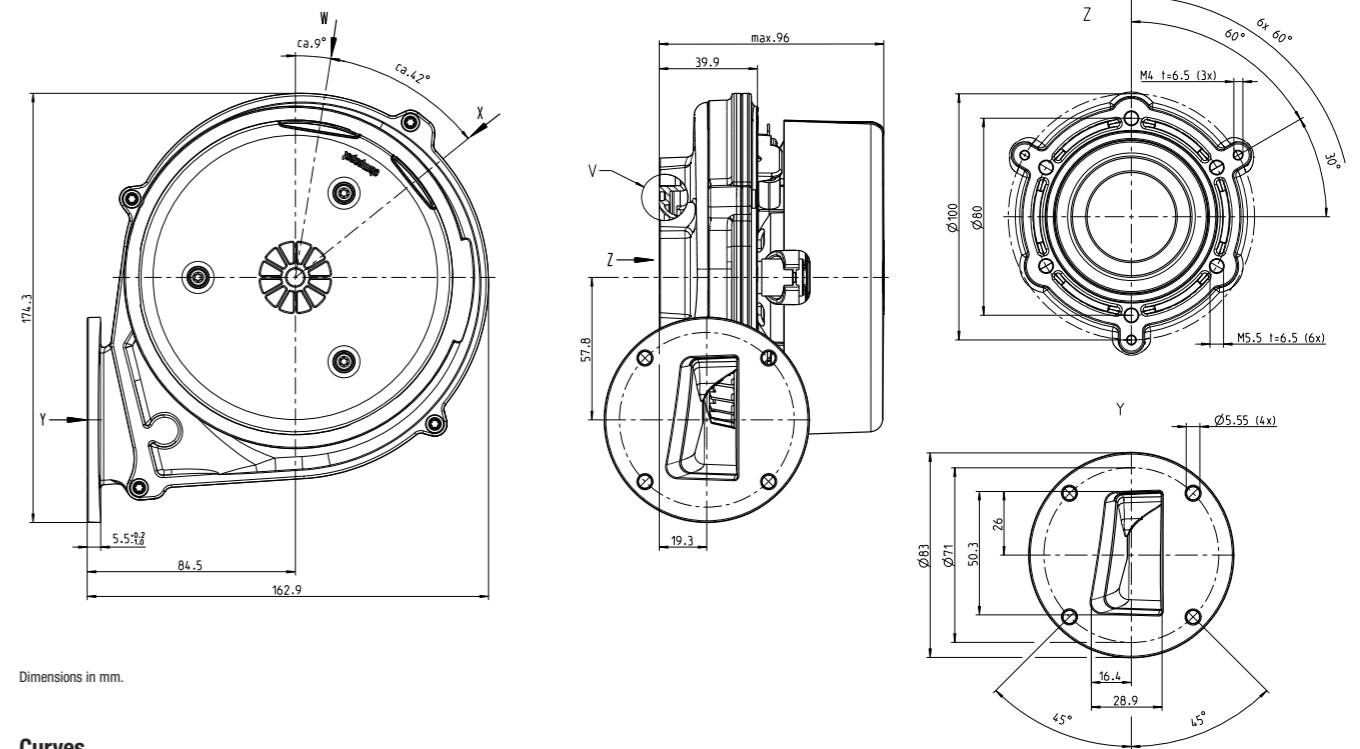
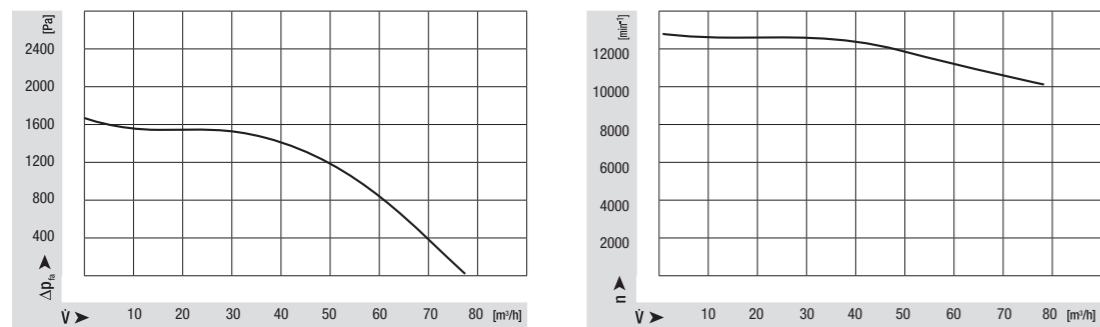

Dimensions in mm.

Curves

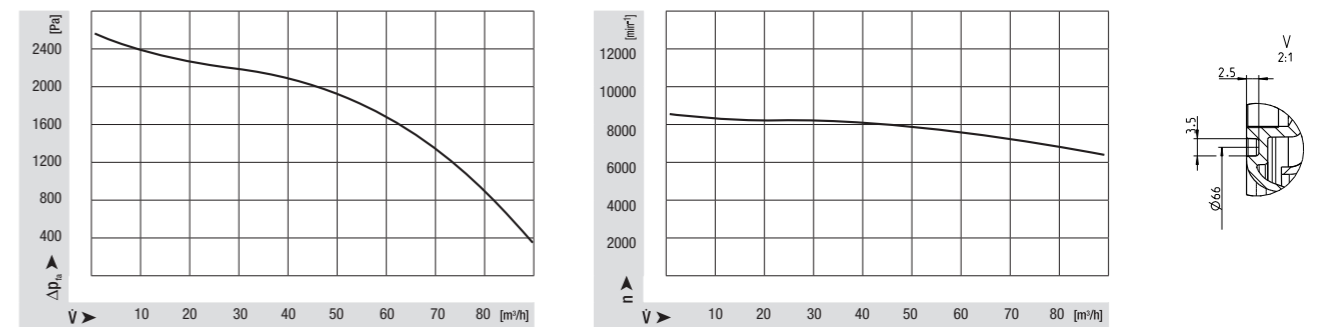

RG 128



- **Material:** Housing: Aluminium
Impeller: Plastic
Motor protection cap: Plastic
- **For potential mounting positions, page 18**
- **Mains connector X, interface connector W and interface see page 31 ff.**

Nominal data	Rated voltage	Frequency	Max. air flow	Max. pressure increase	Max. input power	Max. speed	Perm. amb. motor temp.	Perm. temp. of medium	Part number
Type	V	Hz	m³/h	Pa	W	min ⁻¹	°C	°C	
RG 128	230	50/60	150	2500	110	8400	60	80	55667.22510

Subject to alterations.

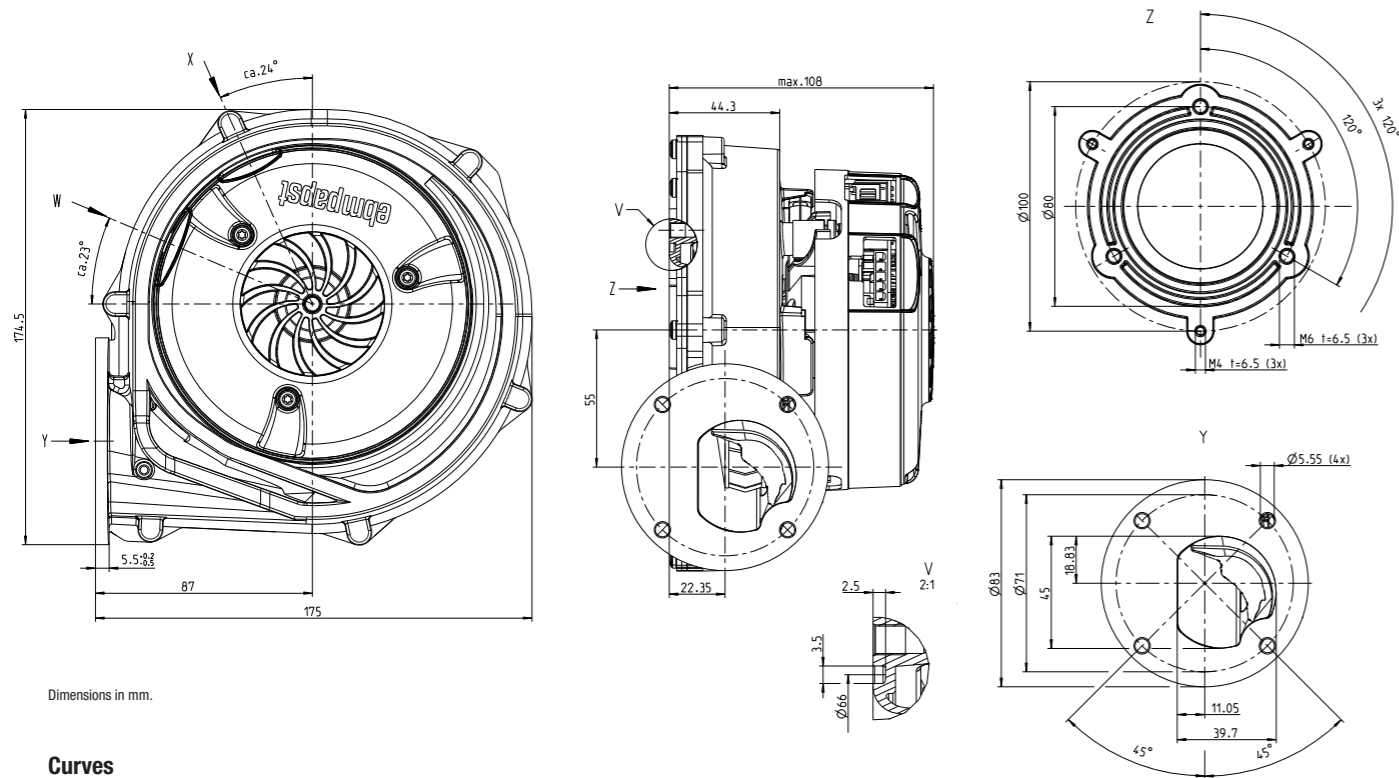

Dimensions in mm.

Curves

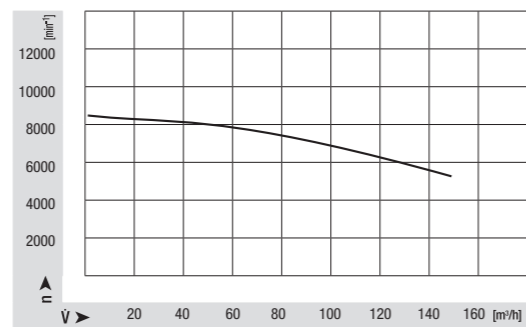
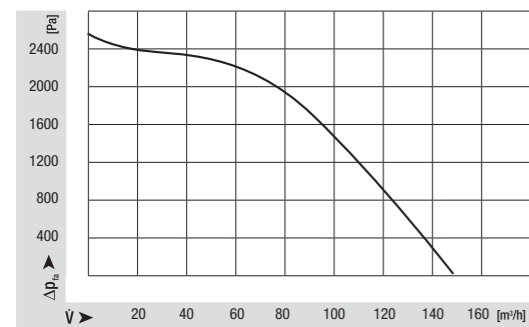

ErP2015 ÜBERTRIFFT DIE NORM

RG 148



- **Material:** Housing: Aluminium
Impeller: Plastic
Motor protection cap: Plastic
- **For potential mounting positions, page 18**
- **Mains connector X, interface connector W and interface see page 31 ff.**

Nominal data	Rated voltage	Frequency	Max. air flow	Max. pressure increase	Max. input power	Max. speed	Perm. amb. motor temp.	Perm. temp. of medium	Part number
Type	V	Hz	m³/h	Pa	W	min ⁻¹	°C	°C	
RG 148	230	50/60	230	4300	200	9500	60	80	55667.25230

Subject to alterations.

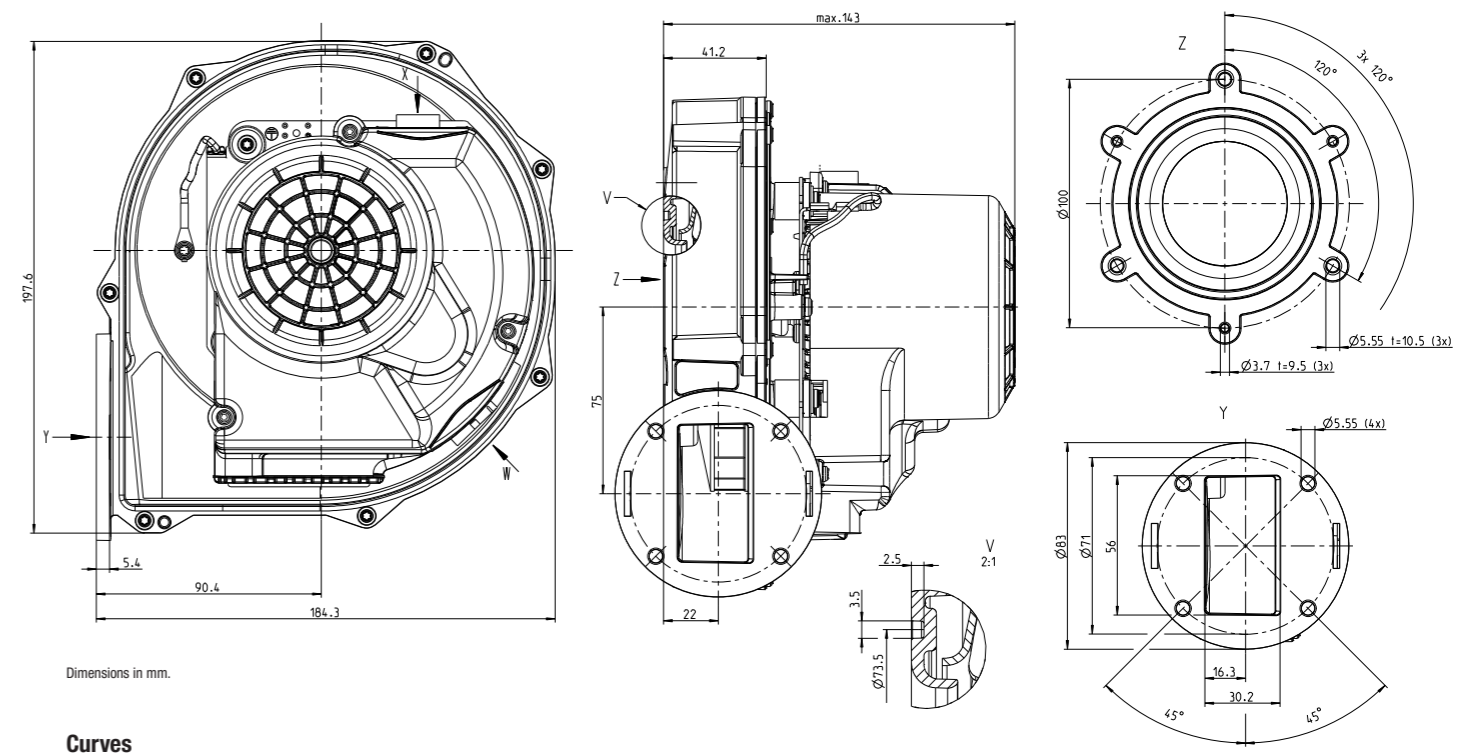

Dimensions in mm.

Curves

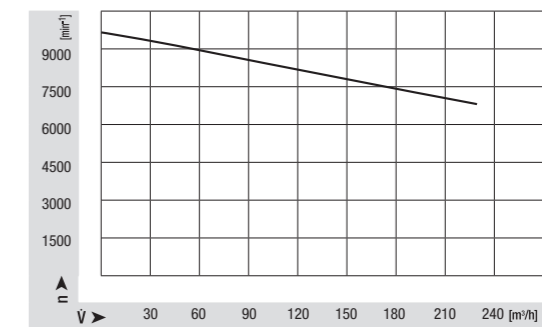
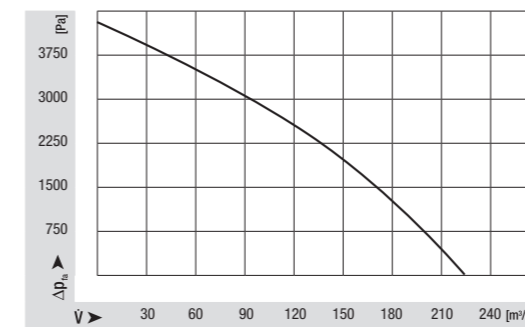

NRG 137



- **Material:** Housing: Aluminium
Impeller: Plastic
Motor protection cap: Plastic
- **For potential mounting positions, page 18**
- **Multi-venturi available**
- **Mains connector X, interface connector W and interface see page 31 ff.**

Nominal data	Rated voltage	Frequency	Max. air flow	Max. pressure increase	Max. input power	Max. speed	Perm. amb. motor temp.	Perm. temp. of medium	Part number
Type	V	Hz	m ³ /h	Pa	W	min ⁻¹	°C	°C	
NRG 137	230	50/60	235	3500	190	9000	60	80	55667.33110

Subject to alterations.

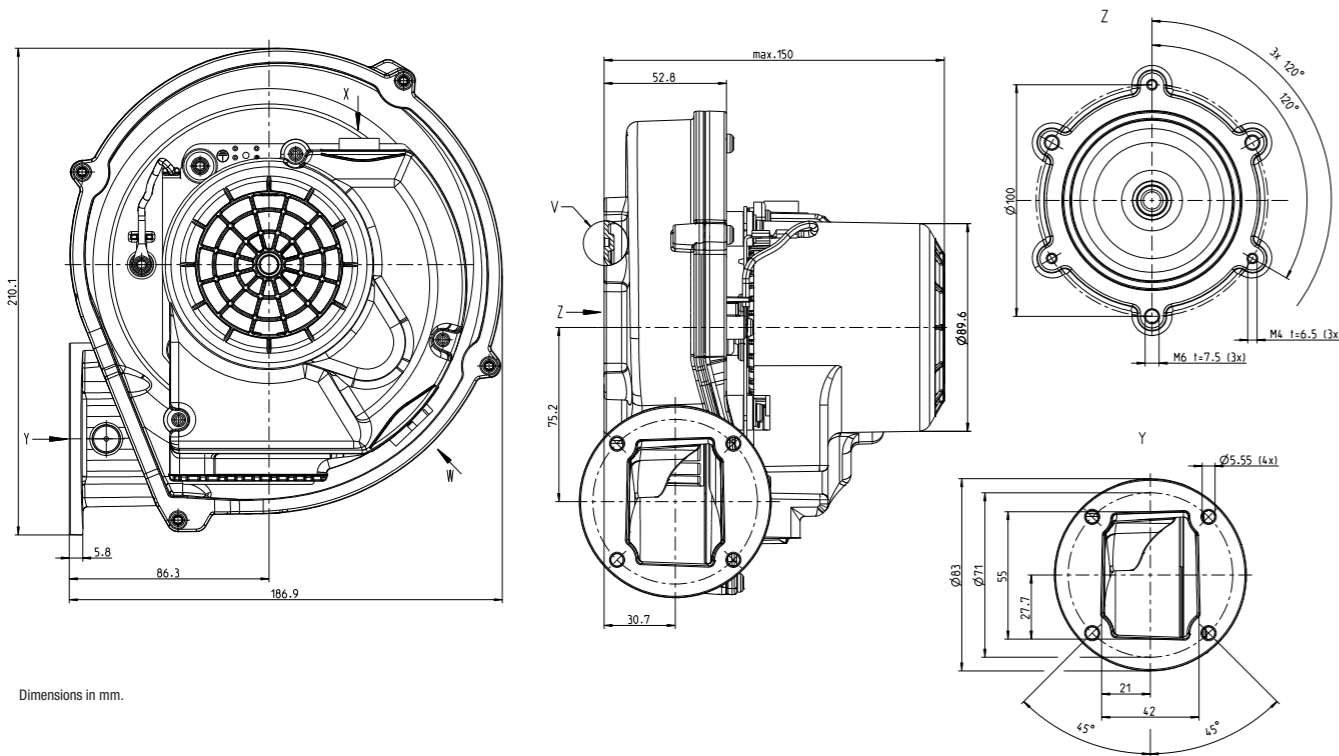

Dimensions in mm.

Curves

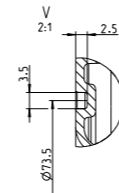
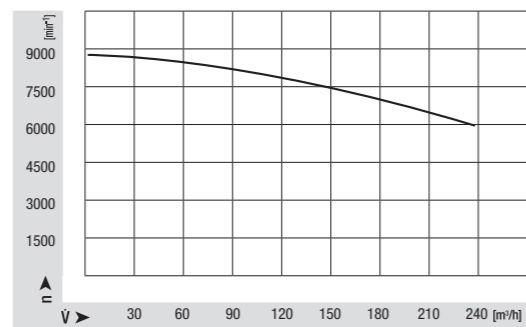
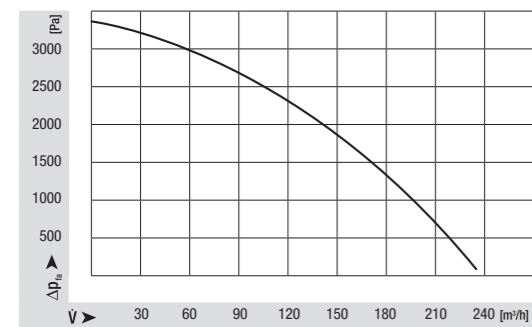

RG 175



- **Material:** Housing: Aluminium
Impeller: Plastic
Motor protection cap: Plastic
- **For potential mounting positions, page 18**
- **Mains connector X, interface connector W and interface see page 31 ff.**

Nominal data	Rated voltage	Frequency	Max. air flow	Max. pressure increase	Max. input power	Max. speed	Perm. amb. motor temp.	Perm. temp. of medium	Part number
Type	V	Hz	m ³ /h	Pa	W	min ⁻¹	°C	°C	
RG 175	230	50/60	390	3700	275	7800	60	80	55667.14090

Subject to alterations.

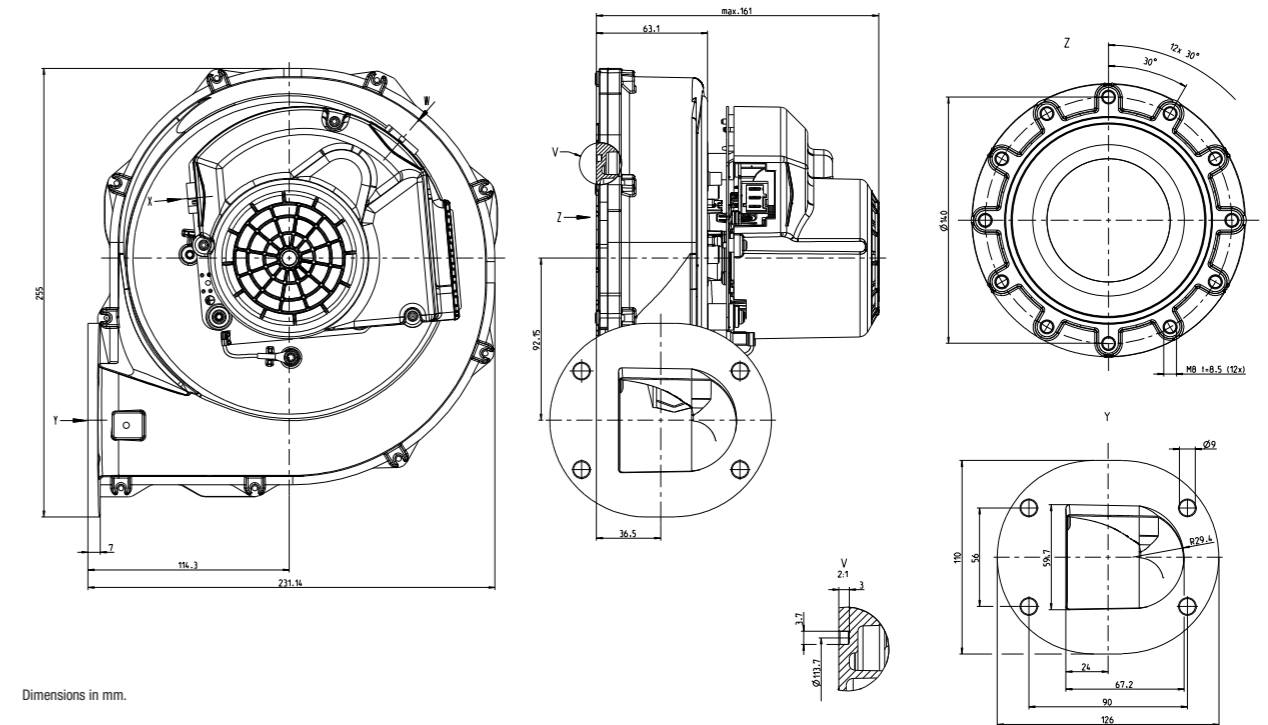

Dimensions in mm.

Curves

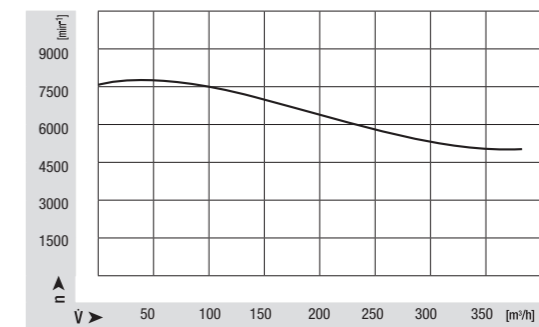
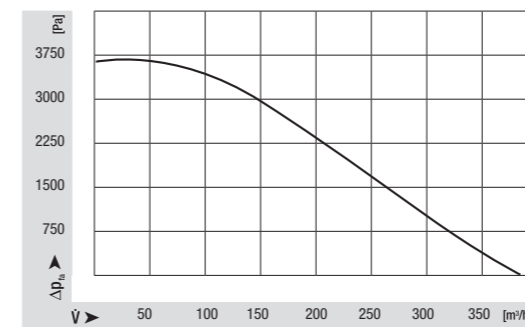

G1G 170



- **Material:** Housing: Aluminium
Impeller: Plastic
Motor protection cap: Plastic
- **For potential mounting positions, page 18**
- **Mains connector X, interface connector W and interface see page 31 ff.**

Nominal data	Rated voltage	Frequency	Max. air flow	Max. pressure increase	Max. input power	Max. speed	Perm. amb. motor temp.	Perm. temp. of medium	Part number
Type	V	Hz	m ³ /h	Pa	W	min ⁻¹	°C	°C	
G1G 170 -AB53-01	230	50/60	620	3000	360	5830	55	80	55600.01270
G1G 170 -AB53-80 ¹	230	50/60	620	3000	360	5830	55	80	55600.01350

Subject to alterations. 1) With linear input (0-10 VDC).

G3G 200



- **Material:** Housing: Aluminium
Impeller: Plastic
Motor protection cap: Plastic
- **For potential mounting positions, page 18**
- **Mains connector X, interface connector W and interface see page 31 ff.**

Nominal data	Rated voltage	Frequency	Max. air flow	Max. pressure increase	Max. input power	Max. speed	Perm. amb. motor temp.	Perm. temp. of medium	Part number
Type	V	Hz	m ³ /h	Pa	W	min ⁻¹	°C	°C	
G3G 200 -GN20-01	230	50/60	1150	2900	890	6100	60	60	55600.03030

Subject to alterations.

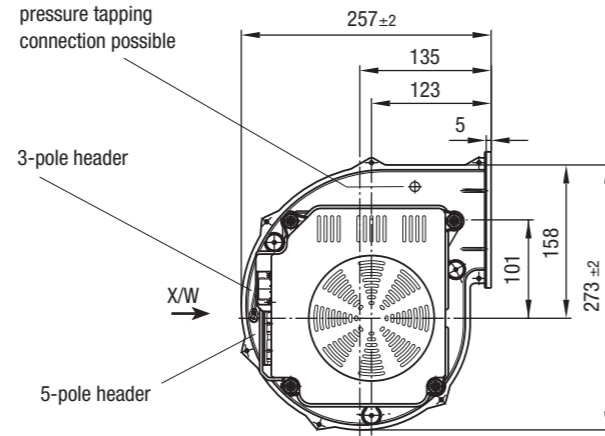
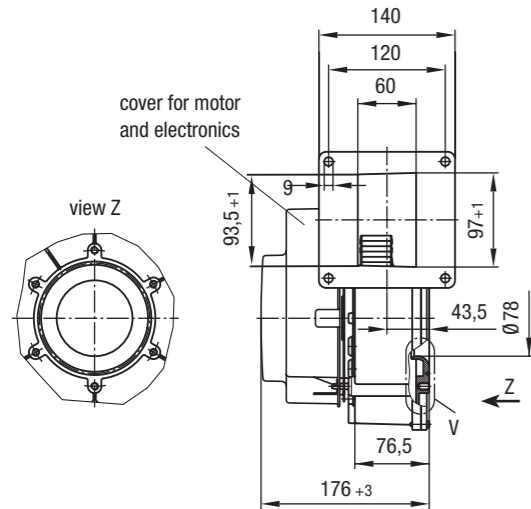

detail V enlarged

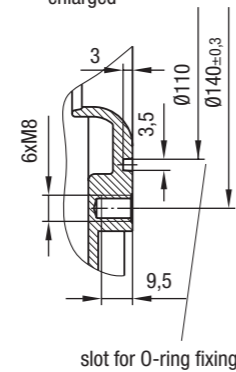

Dimensions in mm.

Curves

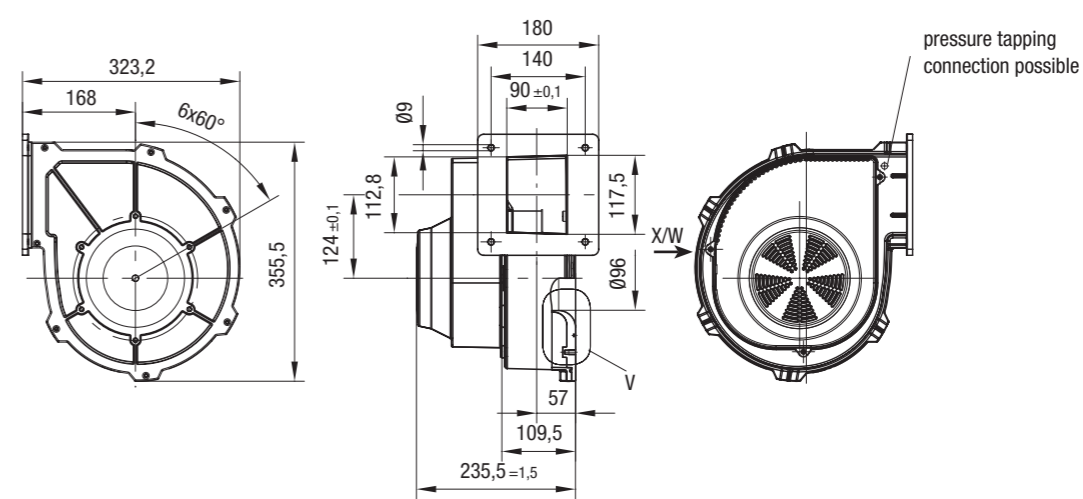
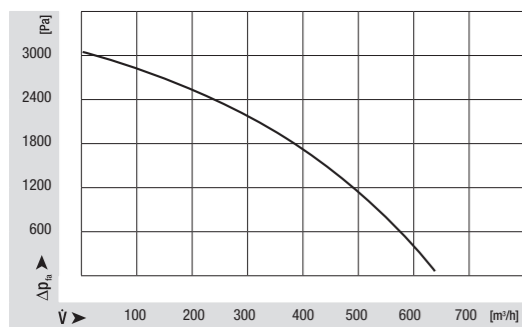

detail V

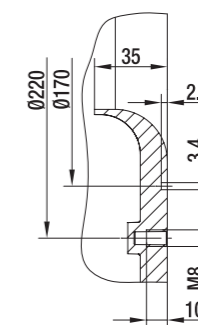

Dimensions in mm.

Curves

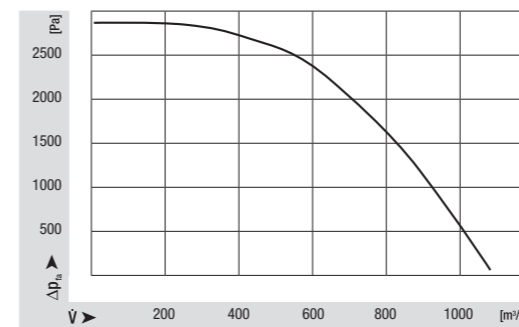

G3G 250

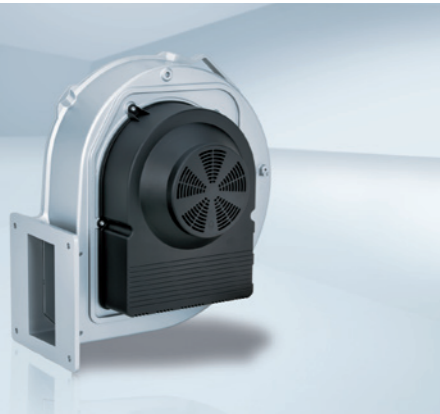

- **Material:** Housing: Aluminium
Impeller: Plastic
Motor protection cap: Plastic
- **For potential mounting positions, page 18**
- **Mains connector X, interface connector W and interface see page 31 ff.**

Nominal data	Rated voltage	Frequency	Max. air flow	Max. pressure increase	Max. input power	Max. speed	Perm. amb. motor temp.	Perm. temp. of medium	Part number
Type	V	Hz	m ³ /h	Pa	W	min ⁻¹	°C	°C	
G3G 250 -GN17-01	230	50/60	1650	3250	1150	4800	60	60	55600.05021

Subject to alterations.

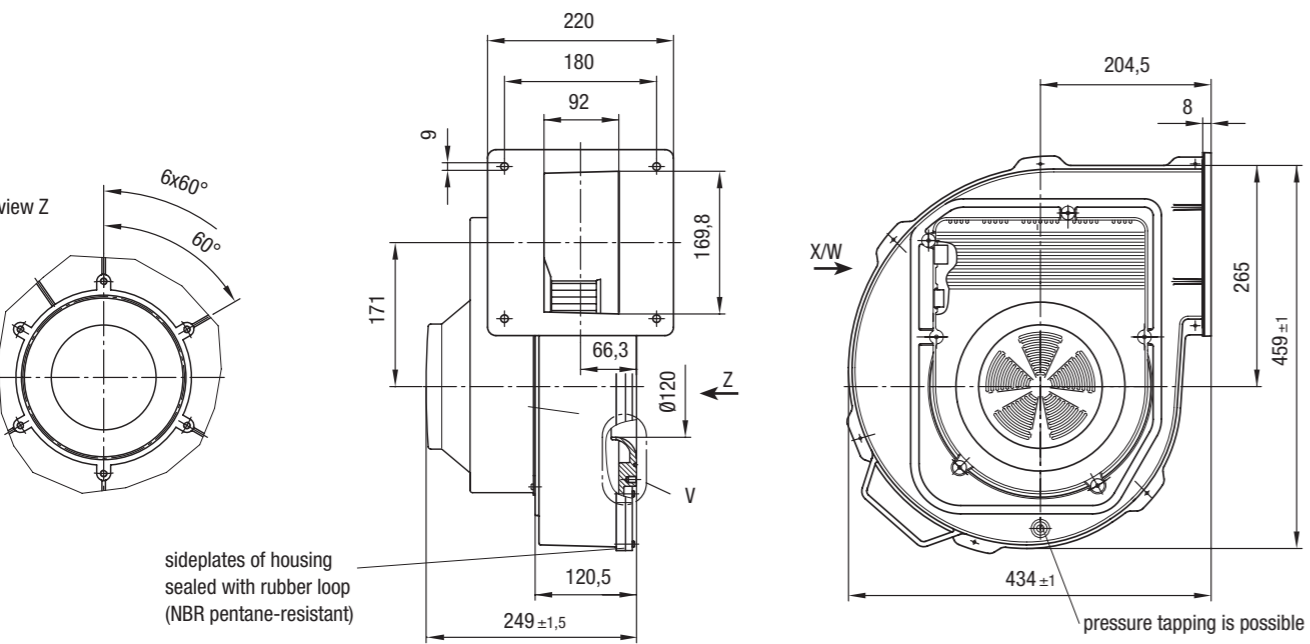

Dimensions in mm.

Curves

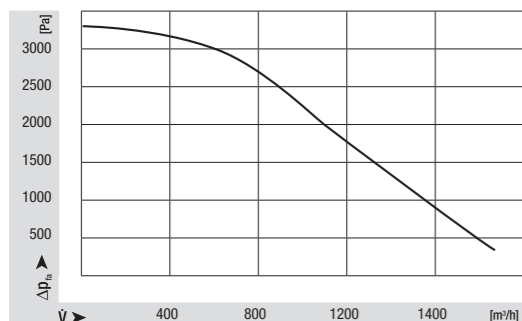

detail V enlarged

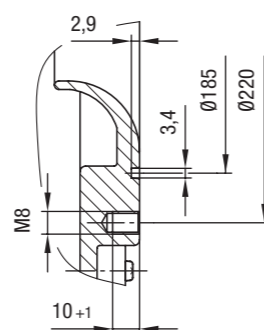

G3G 250 MW



- **Material:** Housing: Die-cast aluminium
Impeller: Sheet aluminium
Rotor: Coated in black
Electronics enclosure: Die-cast aluminium
- **For mains connector see operating instructions**

Nominal data	Rated voltage	Frequency	Max. air flow	Max. pressure increase	Max. input power	Max. speed	Perm. amb. motor temp.	Perm. temp. of medium	Part number
Type	V	Hz	m ³ /h	Pa	W	min ⁻¹	°C	°C	
G3G 250 -MW50-01	380-480	50/60	2200	5400	2500	6400	50	50	G3G 250 -MW50-01

Subject to alterations.

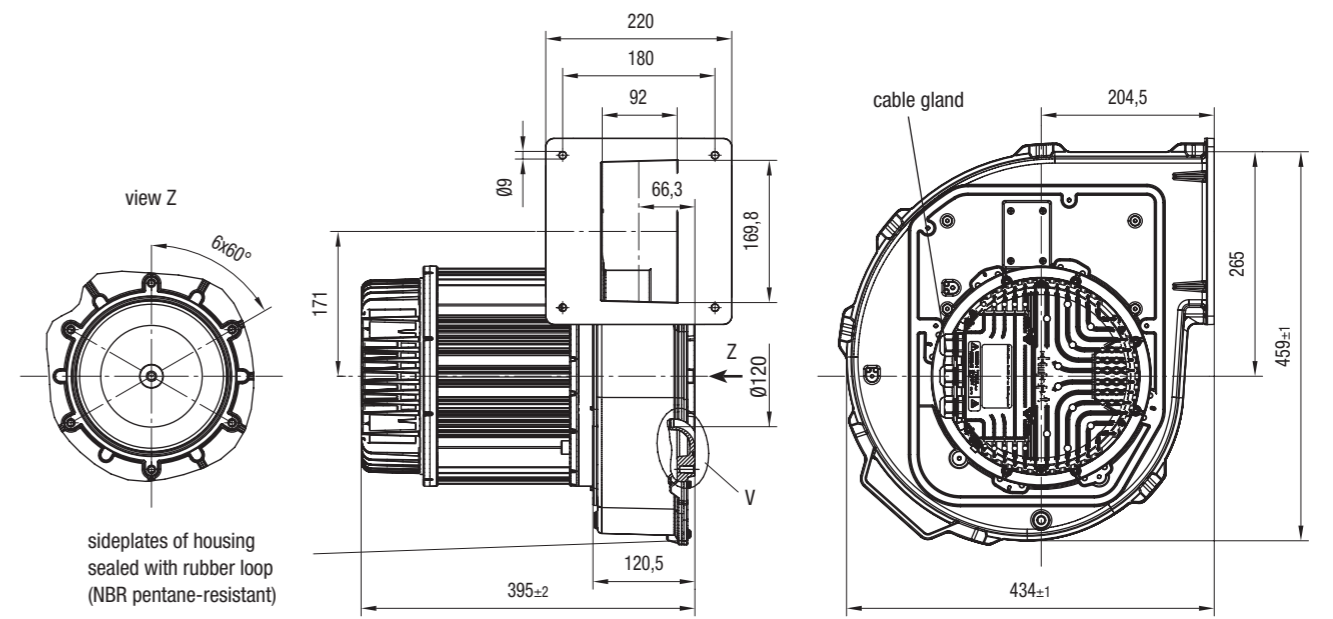

Dimensions in mm.

Curves

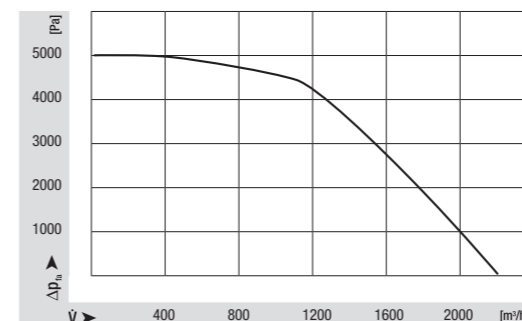

detail V

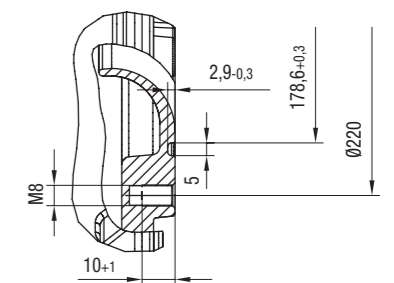

HRG 134

for oil condensing boilers



- **Material:** Housing: Plastic
Impeller: Plastic
Motor protection cap: Plastic
- **For potential mounting positions, page 18**
- **Mains connector X, interface connector W and interface see page 31 ff.**

Nominal data	Rated voltage	Frequency	Max. air flow	Max. pressure increase	Max. input power	Max. speed	Perm. amb. motor temp.	Perm. temp. of medium	Part number
Type	V	Hz	m ³ /h	Pa	W	min ⁻¹	°C	°C	
HRG 134	230	50/60	78	3000	70	8500	60	80	55667.40160

Subject to alterations.

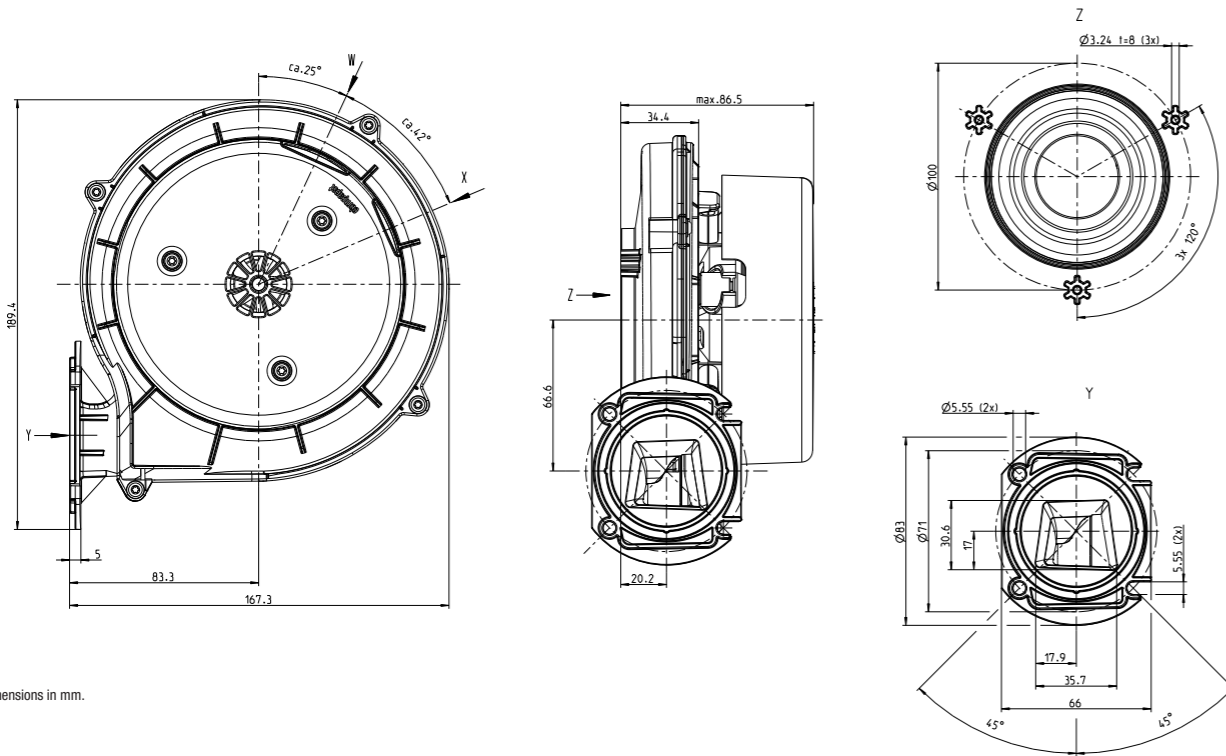

Dimensions in mm.

Curves

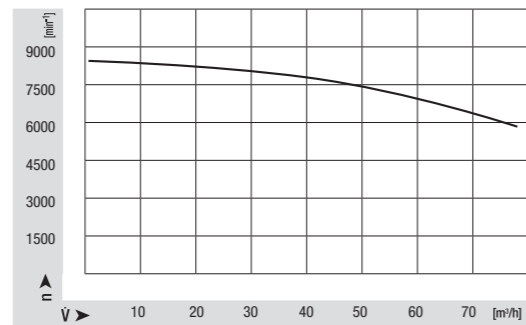
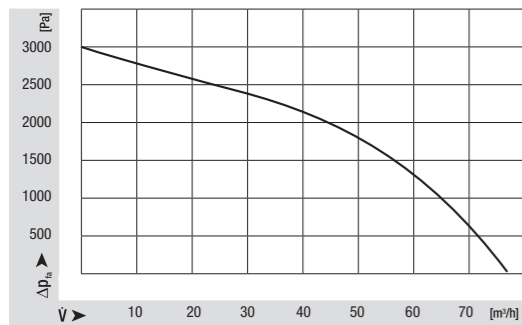

Connectors

Connectors

		NRG 77	NRG 118	RG 128	RG 148	NRG 137	RG 175	G1G 170 -AB53-01	G1G 170 -AB53-80	G3G 200	G3G 250	HRG 134	G3G 250 MW	Interface 04600.451...
1	Mains connector X	x	x	x	x	x	x					x		
2	Mains connector X							x	x	x	x			
3	Interface connector W	x												31
4	Interface connector W		x	x	x	x	x					x		04
5	Interface connector W							x						38
6	Interface connector W								x	x	x			39

see operating instructions

Further connector types on request.

1 Mains connector X

3-pin pin-connector with coding type 0A according to RAST 5 in 90° angled / horizontal design with locking feature on top or down for locking device suitable for mating connector according to RAST 5 with coding type 0A as e. g. CoHaMo YY-A5002-H03-K01 or Lumberg 3623 03 K01 Part number for mating connector: 24310.45025

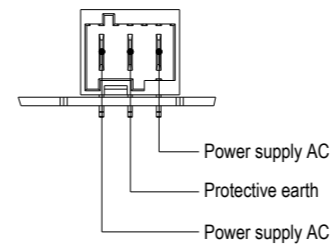

2 Mains connector X

3-pin pin-connector according RAST 6.35 in 90° angled / horizontal design suitable for mating connector according to RAST 6.35 e. g. Tyco Universal MATE-N-LOK order number: 1586847-1 and 3 x socket 926882-1 Part number for mating connector: Connector shell 24309.45012; Crimp socket 24307.45002/3

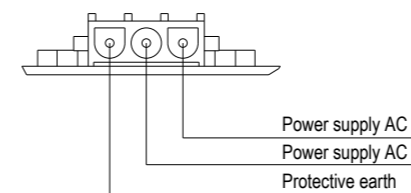

3 Interface connector W

4-pin pin-connector according RAST 3.0 in 90° angled / horizontal design suitable for mating connector according to RAST : e. g. Molex Micro-Fit 3.0 order number: 43645-0408 and 4 x socket 43030-0001 Part number for mating connector: Connector shell 24310.45133; Crimp socket 24300.45128

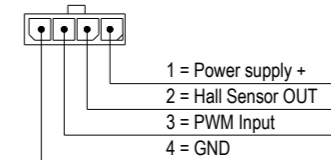

4 Interface connector W

5-pin pin-connector according RAST 4.2 in 90° angled / horizontal design suitable for mating connector according to RAST 4.2 e. g. Stocko STO-FIT, CoHaMo order number: Stocko EH 705-005-004-960 and 5 x socket RBB 8230.120 order number: CoHaMo YY-5700-H05AS-GW Part number for mating connector: Connector shell 24309.45035; Crimp socket 24308.45065

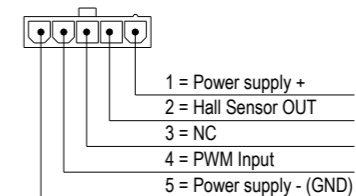

5 Interface connector W

5-pin pin-connector according RAST 4.2 in 90° angled / horizontal design suitable for mating connector according to RAST 4.2 e. g. Stocko STO-FIT, CoHaMo order number: Stocko EH 705-005-004-960 and 5 x socket RBB 8230.120 order number: CoHaMo YY-5700-H05AS-GW Part number for mating connector: Connector shell 24309.45035; Crimp socket 24308.45065

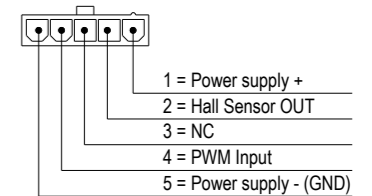

6 Interface connector W

5-pin pin-connector according RAST 4.2 in 90° angled / horizontal design suitable for mating connector according to RAST 4.2 e. g. Stocko STO-FIT, CoHaMo order number: Stocko EH 705-005-004-960 and 5 x socket RBB 8230.120 order number: CoHaMo YY-5700-H05AS-GW Part number for mating connector: Connector shell 24309.45035; Crimp socket 24308.45065

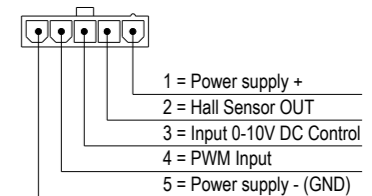

Electrical interfaces

Interface 31

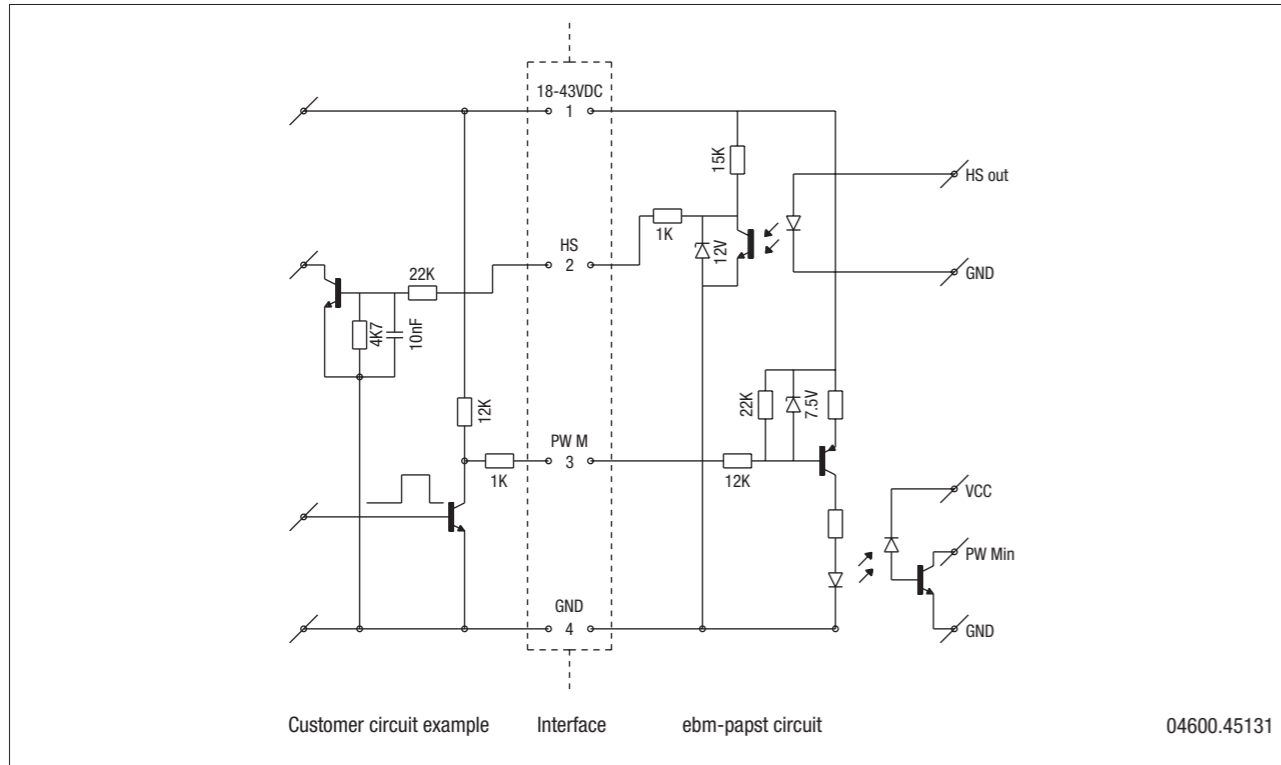

Electrical interfaces

Interface 38 115/230 VAC

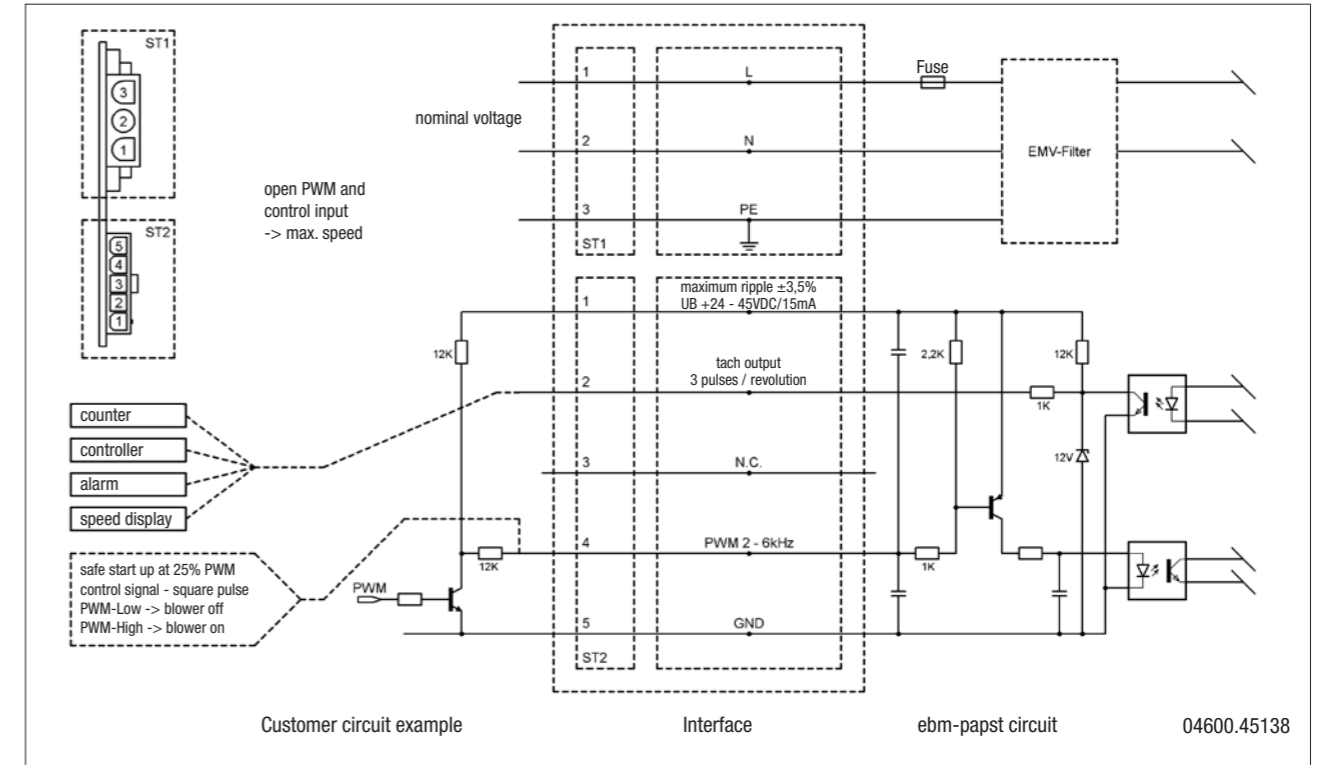

Interface 04 230 VAC, 50/60 Hz 120 VAC, 50/60 Hz control

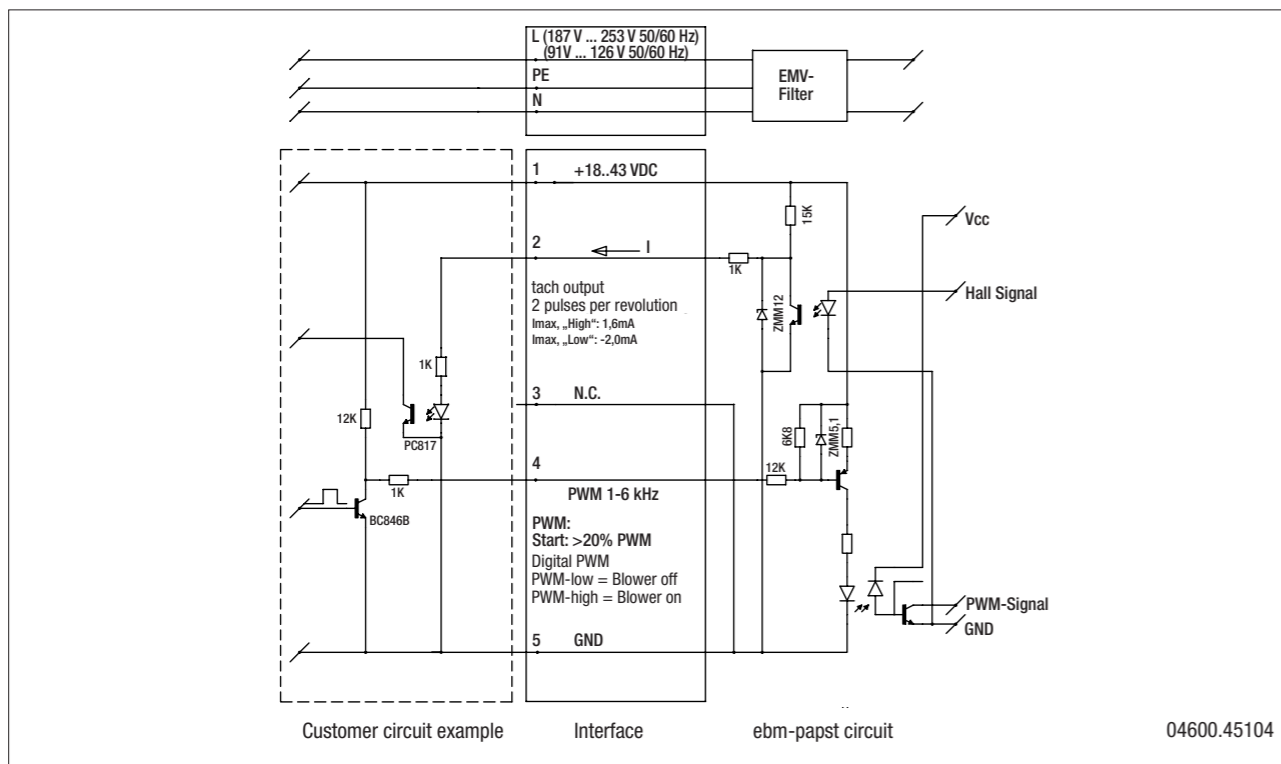

Interface 39 115/230 VAC

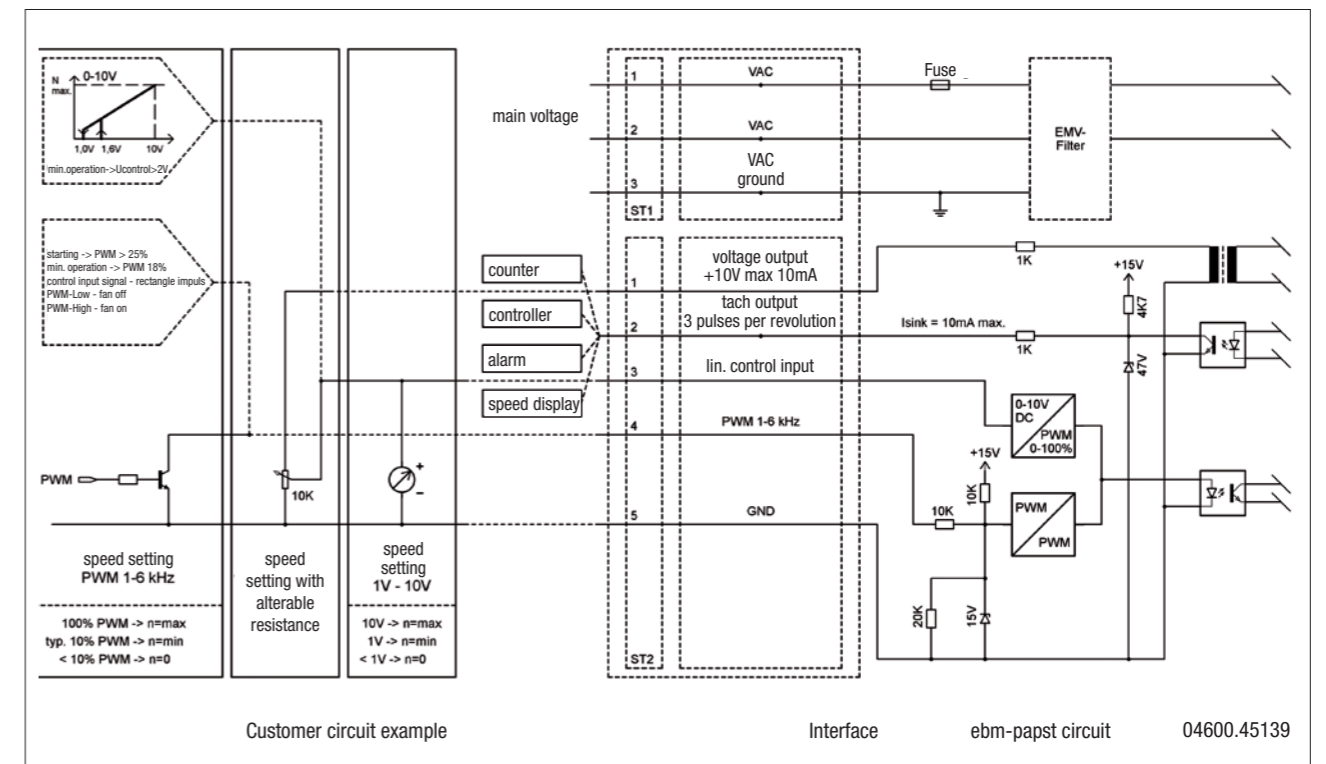

Further types on request.

Further types on request.

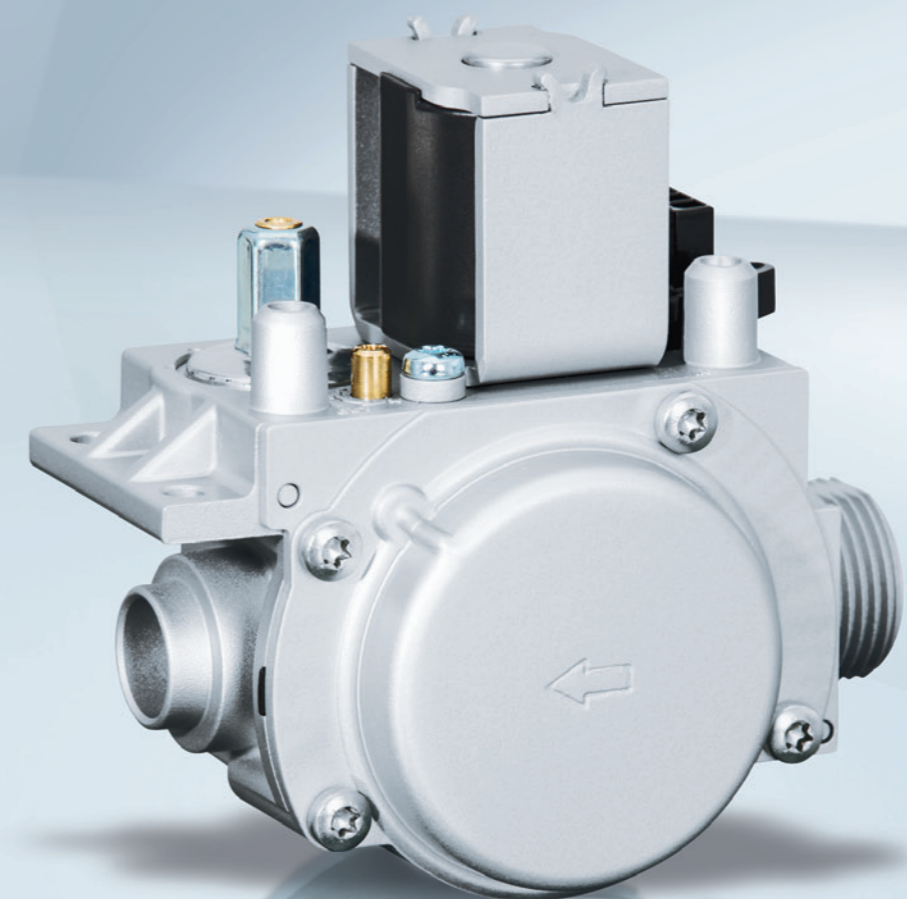

Our zero-pressure gas valves for gas-condensing systems are primarily used for domestic applications in the lower and medium power range. These gas valves compensate for pressure fluctuations occurring in the public gas grid as well as regulate the offset pressure to zero regardless of the suction pressure being generated by a premix blower. The offset (zero point shift) can be configured at the servo regulator. At the same time the desired gas quantity can be adjusted by using an integrated throttle element. Both together ensure an accurate air-gas ratio setting. Depending on the design a reference pressure can be connected to the servo regulator if required.

Technical information

Length	105mm
Permitted gas families	II + III (in accordance with EN 437)
Maximum inlet pressure	65mbar (CE), 0,5psi (CSA)
Permitted ambient temperature	0°C to 60°C (-15°C to 70°C on request)
Permitted storage temperature	-25°C to 70°C
Type of protection	IP40 in combination with a suitable plug
Offset correction	+/- 20Pa
Minimum signal pressure	-30Pa
Permitted mounting position	Solenoid at any position between vertical and horizontal – but not upside down.

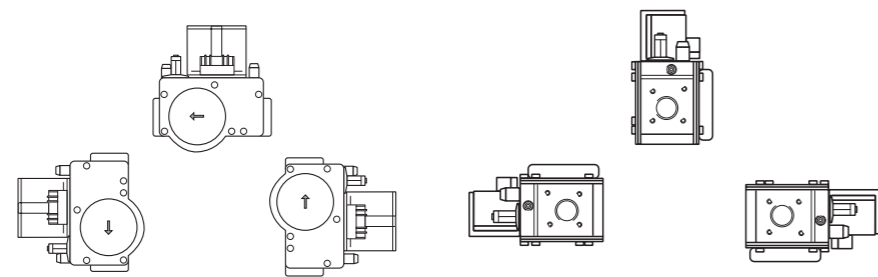

Type examination certificate in accordance with EC Gas Appliances Directive: CE 0085CM0036 (product ID number)

Applicable standards

- EN126:2012 06: Multifunctional controls for gas burning appliances
- EN13611:2007 + A2:2011: Safety and control devices for gas burners and gas burning appliances – General requirements
- EN161:2012 08: Automatic shut-off valves for gas burners and gas appliances
- EN88-1:2011: Pressure regulators and associated safety devices for gas appliances – Part 1: Pressure regulators for inlet pressures up to and including 50kPa

Type examination certificate for North America (USA and Canada): Master Contract No. 172723

Applicable standards

- ANSI Z21.78 2010 / CSA 6.20 2010: Combination Gas Controls for Gas Appliances

Approvals exist for the chief gas consuming countries.

Additional notes

- Work on the gas valve may be performed by authorised specialists only.
- Please be sure to observe the corresponding installation instructions.
- Corresponding documents with safety instructions are available upon request or on the Internet.

E01

Size GB055



- **Housing:** Aluminium
- **Electrical connection:** Connector shell with 4.20mm grid
- **Inlet (gas connection):** External thread G3/4 or G1/2 (DIN EN ISO 228) or 4 x M4 mounting holes (optional)
- **Outlet:** ebm-papst specific quick-connector
- **Safety valves:** Coaxial design: valve class B/C in accordance with EN161

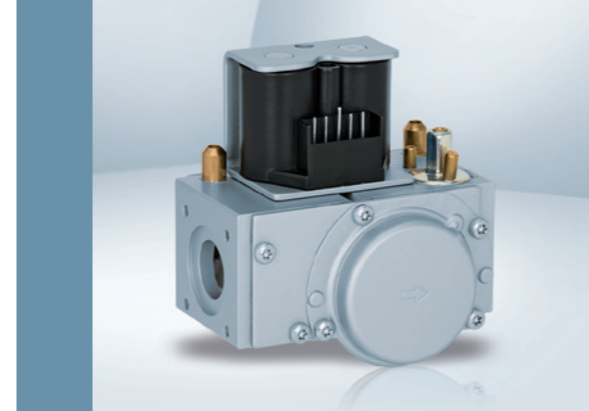

D01

Size GB057

- **Housing:** Aluminium
- **Electrical connection:** Connector shell with 5.08mm grid
- **Inlet (gas connection):** 4 x M5 mounting holes (36mm hole spacing)
- **Outlet:** 4 x M5 mounting holes (36mm hole spacing)
- **Safety valves:** Valve class B/B in accordance with EN161

Nominal data	Rated voltage	Max. input power	Nominal diameter	Maximum inlet pressure	Flow rate (at $\Delta p = 5\text{mbar}$)	Automatic shutoff valves (EN161)	Minimum signal pressure	Opening and closing time
Type	V	VA	mbar	m ³ /h	Pa	s		
GB-ND 055 E01	230 RAC	9.8	DN15/20	65	3.4	Class B/C	-30	< 1
	120 RAC	9.8	DN15/20	65	3.4	Class B/C	-30	< 1
	24 RAC	9.8	DN15/20	65	3.4	Class B/C	-30	< 1
	24 DC	9.8	DN15/20	65	3.4	Class B/C	-30	< 1
	22 DC	9.8	DN15/20	65	3.4	Class B/C	-30	< 1

Nominal data	Rated voltage	Max. input power	Nominal diameter	Maximum inlet pressure	Flow rate (at $\Delta p = 5\text{mbar}$)	Automatic shutoff valves (EN161)	Minimum signal pressure	Opening and closing time
Type	V	VA	mbar	m ³ /h	Pa	s		
GB-ND 057 D01	230 RAC	2 x 12.5	DN20	65	5.3	Class B/B	-30	< 1
	120 RAC	2 x 12.5	DN20	65	5.3	Class B/B	-30	< 1
	24 RAC	2 x 12.5	DN20	65	5.3	Class B/B	-30	< 1
	24 DC	2 x 12.5	DN20	65	5.3	Class B/B	-30	< 1

Capacity curve – GB055

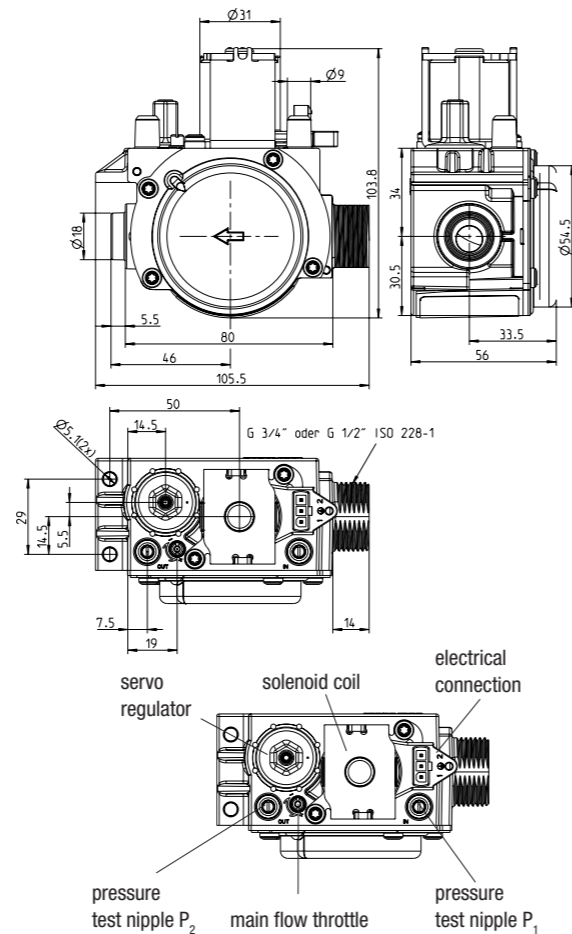
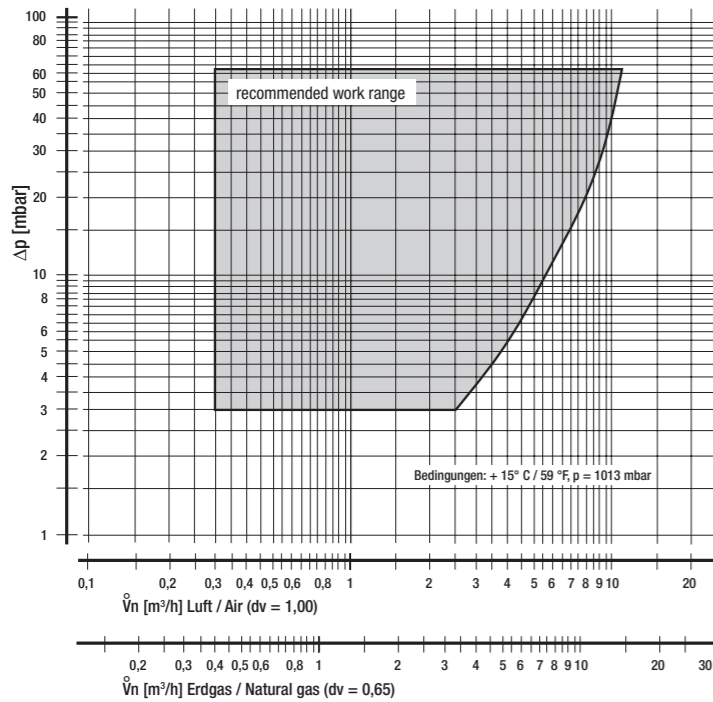

Capacity curve – GB057

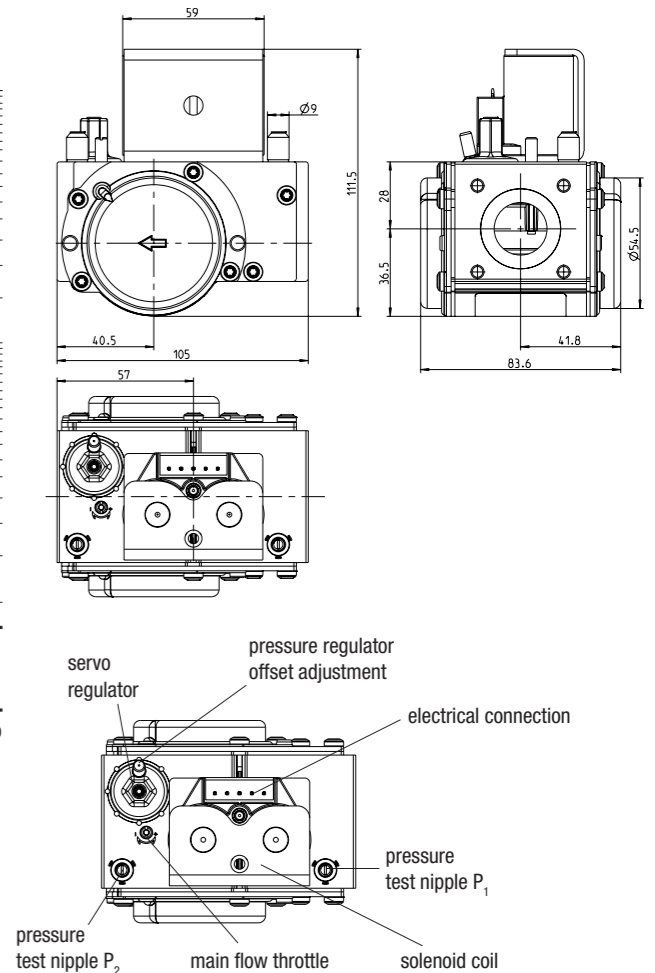
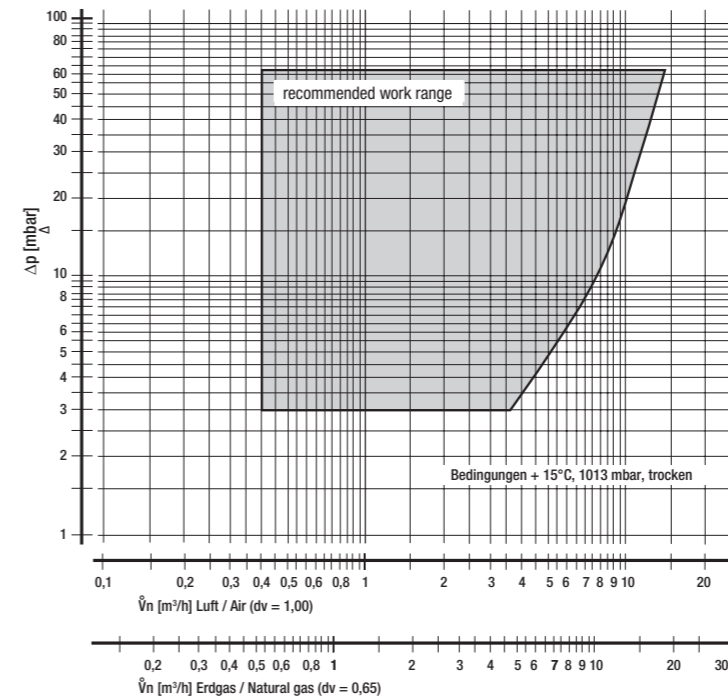

F01

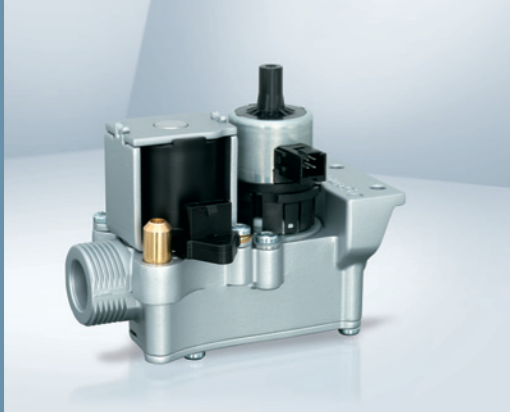

- **Housing:** Aluminium
- **Electrical connection:** Connector shell with 4.20mm grid
- **Inlet (gas connection):** External thread G3/4 or G1/2 (DIN EN ISO 228)
- **Outlet:** ebm-papst specific quick-connector
- **Safety valves:** Coaxial design: valve class B/C in accordance with EN161

Nominal data	Rated voltage	Max. input power	Nominal diameter	Maximum inlet pressure	Flow rate (at $\Delta p = 5\text{mbar}$) Stepper motor module with nominal diameter 8mm	Flow rate (at $\Delta p = 5\text{mbar}$) Stepper motor module with nominal diameter 12mm	Automatic shutoff valves (EN161)	Opening and closing time
Type	V	VA		mbar	m ³ /h	m ³ /h		s
GB-SXX 06X F01	230 RAC	9.8	DN15/20	60	2.1	2.9	Class B/C	< 1
	120 RAC	9.8	DN15/20	60	2.1	2.9	Class B/C	< 1
	24 RAC	9.8	DN15/20	60	2.1	2.9	Class B/C	< 1
	24 DC	9.8	DN15/20	60	2.1	2.9	Class B/C	< 1
	22 DC	9.8	DN15/20	60	2.1	2.9	Class B/C	< 1

Capacity curve – F01

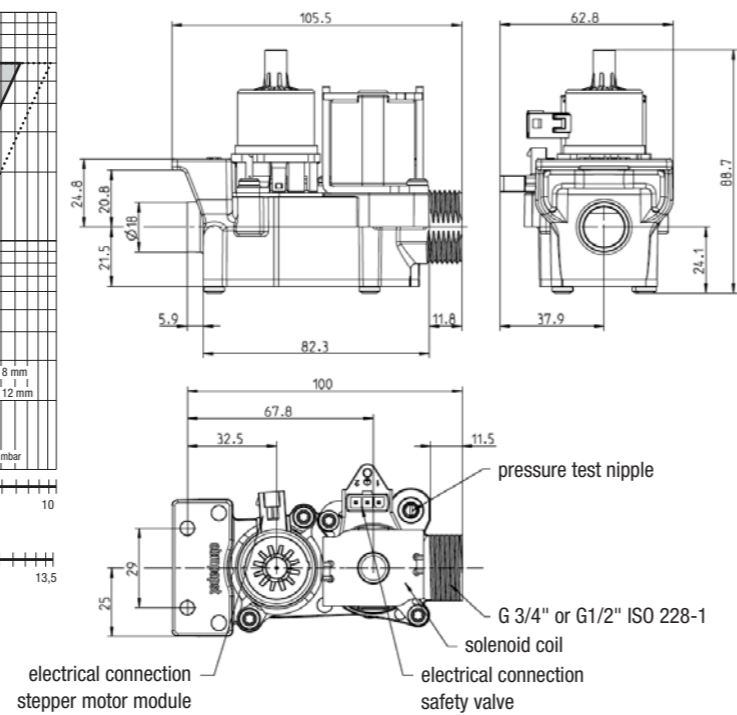
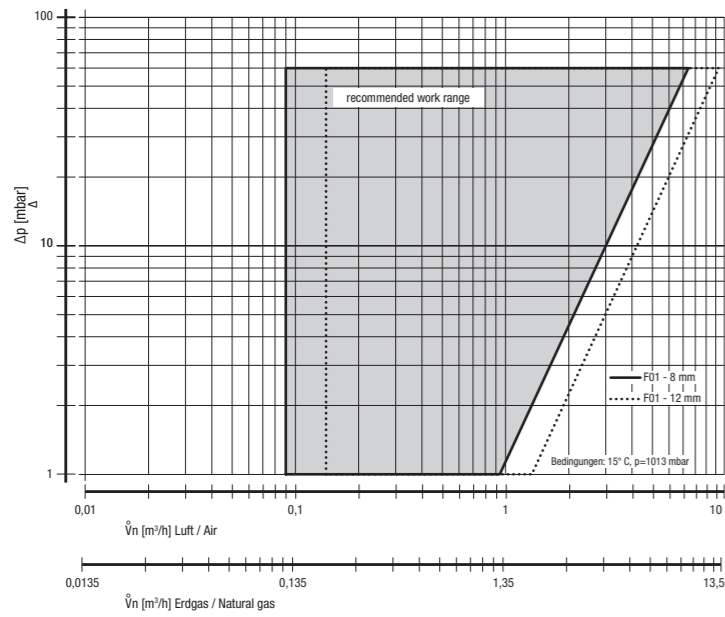



Burner Controls

In co-operation with the Dutch electronic control unit specialist ebmpapst Heating Systems B.V. (formerly Argus Vision B.V.), we also offer our customers a control element for their gas heaters from a single source. ebm-papst Heating Systems already has 20 years of experience in developing burner controls to look back on and also has the required expertise for mastering the current challenges in condensing boiler technology. In modulating condensing boilers, the link between mechanical components and the electronic drive has to be co-ordinated with a high-degree of precision in order to achieve optimum combustion behaviour. ebm-papst Heating Systems earned a reputation for the highest innovative strength and quality in electronic monitoring for gas-fires heating systems.



ebm-papst Heating Systems supplies the electronics for controlling ignition, performance regulation and monitoring the function of the condensing boiler as well as a user input interface with various displays for conveniently controlling central heating and DHW. The burner control can also be used in combination with other modules and provide control with a system regulation, for example a cascade operation.

The standard platform, consisting of tried-and-tested hardware and software, enables reliable operating performance and short development cycles. The versatile software architecture enables customer-specific interfaces to be integrated with ease. In addition, as with our blowers, we value having the lowest possible energy consumption.

System in operation

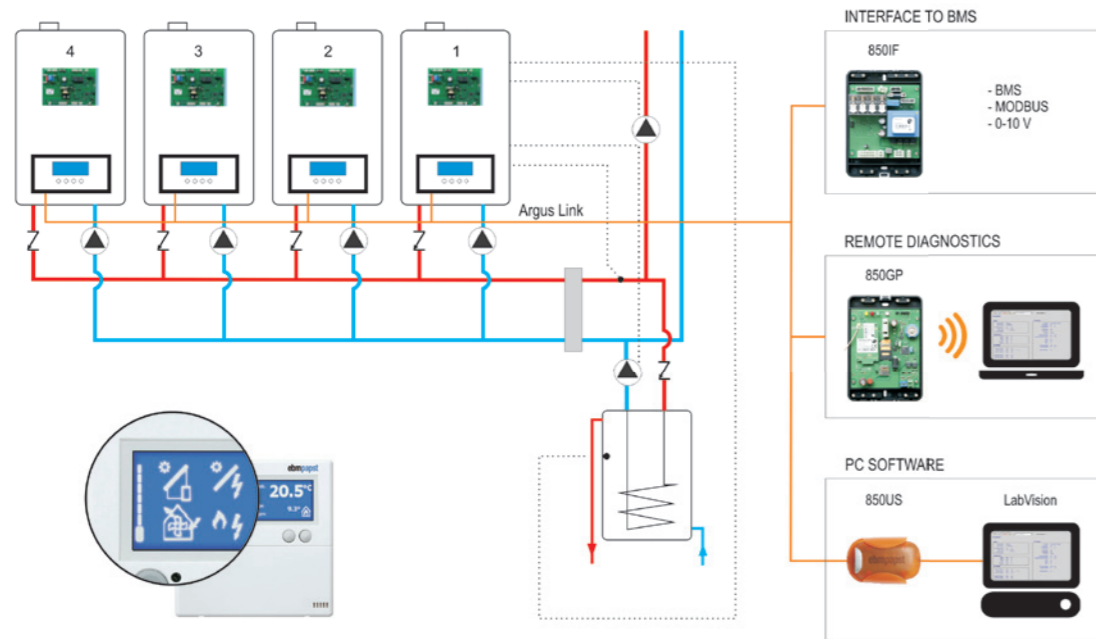

Trio / Multiple Trio Application

Markets and application areas

Gas fired combi-boilers, commercial gas boilers, air heaters, direct fired water heaters, indirect fired water heaters, gas stoves, catering equipment such as fryers and mCHP.

Service tools

LabVision computer software for communication between computer and burner control.

Burner Control Units



- **Function:** To control central heating, DHW, cascade operation, multiple burners (trio and multiple trio). No additional controller needed.
- **Application:** Domestic (combi) boilers, commercial boilers, water heaters
- **Connections:** Supports a wide range of in- and outputs for sensors, valves, ignition, pumps, etc.
- **Support:** LabVision PC Software, to configure hard- and software functions, remote diagnostics, logging and graphs

Nominal data	Power supply	Frequency	Dimensions housing l x w x h	Safety time	Ignition attempts	Weight	On Board User Interface	Event history (error & lockout)	Argus Link	LabVision Diagnostics Software
Type	VAC	Hz	mm	Sec.		gram				
850MN	230	40-70	212 x 152 x 46	6	3	530	No	15 + 15	x	x
850MN	120	40-70	212 x 152 x 46	6	3	530	No	15 + 15	x	x
900MN	230	40-70	212 x 152 x 49	6	3	512	Yes	15 + 15	x	x

Features

- Low standby power consumption and class A modulating pump control
- Insensitivity of mains supply for a reliable operation
- Thermostat options: Switched Live, OT-interface or 24V
- Connect controls with each other via Argus Link (2-wire communication interface)
- Wide choice of control modules for hybrid heating applications and systems within a building or house
- Easy interfacing with Building Management Systems, for example via ModBUS

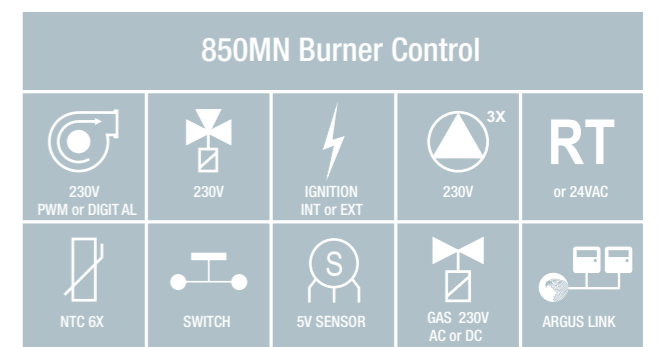
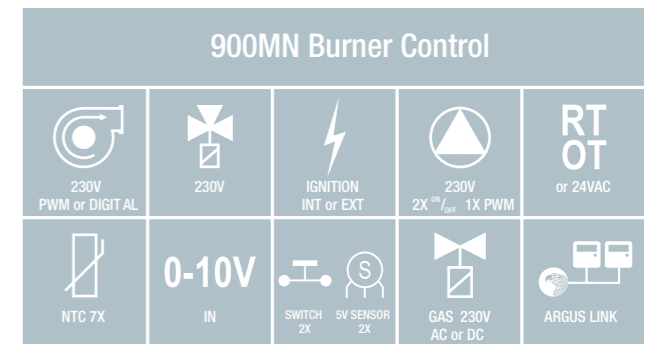

Displays

- **Function:** External display modules to be used as an user interface for burner controls or optional modules
- **Integrated features:** User and installer menu, multiple languages and graphics
- **Optional features:** Specific application menus, for example solar control and catering equipment
- **2 Wire Argus Link:** One connection for power and communication



Optional Modules

- **Function optional modules:** Add-on modules to extend your system
- **Argus Link Interface:** To connect easily to other controls
- **Support:** RemoteVision PC Software, for monitoring, controlling and data-logging of field appliances via a permanent TCP/IP internet connection (also available as SiteVision for installers)

Nominal data	Dimensions (l x w x h)	LCD type	Display Color	Backlight	LCD display Area (l x h)	No. of Push Buttons	Available with housing	Connection	Multiple languages	Temp. Sensor	Real Time Clock
Type	mm				mm						
900PB	178 x 85 x 13	Pixel 255 x 80	blue/white	x	106.4 x 39	8		2-wire	x		x
900DI	142 x 63.5 x 29	Icons & segment	green/black	x	37 x 22	5		2-, 3- or 4-wire			
900LB	119 x 115 x 20	Icons & segment	blue/white	x	93 x 31	5		2- or 4-wire		optional	
850HC	129 x 129 x 24	Pixel 255 x 80	blue/white	x	106.4 x 39	11	x	2-wire	x	x	x

Nominal data	Power Supply	Dimensions (l x w x h)	Weight	Argus Link
Type	VAC	mm	gram	
850DS		87 x 50 x 27	45	x
850IF	110V/230	155 x 110 x 51	439	x
850SC	110V/230	150 x 105 x 14	525	x
850GP	110V/230	150 x 105 x 14	254	x
850USB		78 x 54 x 28	116	x

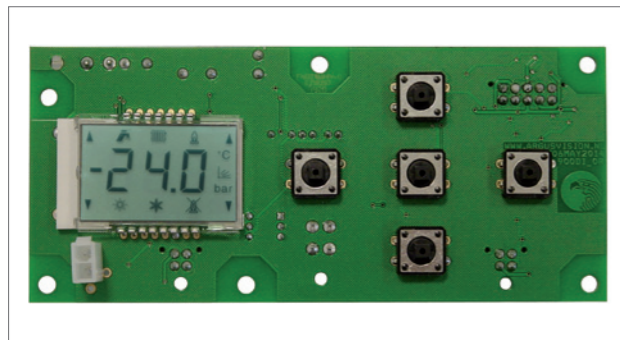

900DI LCD Display

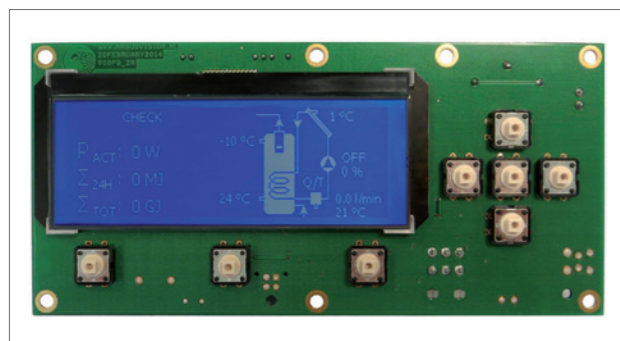

900PB Pixel Display



900LB LCD Display



850SC Solar Control
Control for thermal solar heat systems with or without drainback tank



850GP GPRS Communication Module
Wireless communication module using GPRS technology



850DS Digital Sensor
Robust outdoor or room temperature sensor



850USB PC Communication Interface
For communication between the PC/LabVision and the control

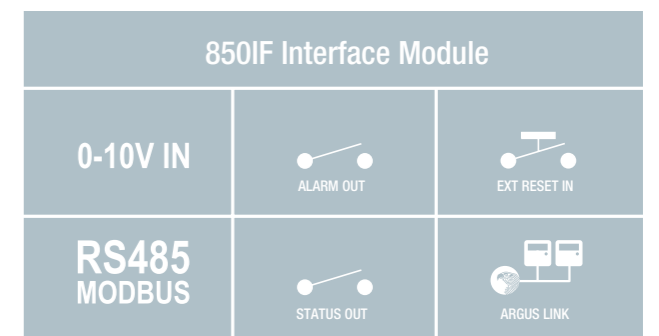

850IF Interface Module
Interface Module to extend several heat generation control modules



850SC Solar Control
Control for thermal solar heat systems with or without drain-back tank

По вопросам продаж и поддержки обращайтесь:

Архангельск (8182)63-90-72	Калининград (4012)72-03-81	Нижний Новгород (831)429-08-12	Смоленск (4812)29-41-54
Астана +7(7172)727-132	Калуга (4842)92-23-67	Новокузнецк (3843)20-46-81	Сочи (862)225-72-31
Белгород (4722)40-23-64	Кемерово (3842)65-04-62	Новосибирск (383)227-86-73	Ставрополь (8652)20-65-13
Брянск (4832)59-03-52	Киров (8332)68-02-04	Орел (4862)44-53-42	Тверь (4822)63-31-35
Владивосток (423)249-28-31	Краснодар (861)203-40-90	Оренбург (3532)37-68-04	Томск (3822)98-41-53
Волгоград (844)278-03-48	Красноярск (391)204-63-61	Пенза (8412)22-31-16	Тула (4872)74-02-29
Вологда (8172)26-41-59	Курск (4712)77-13-04	Пермь (342)205-81-47	Тюмень (3452)66-21-18
Воронеж (473)204-51-73	Липецк (4742)52-20-81	Ростов-на-Дону (863)308-18-15	Ульяновск (8422)24-23-59
Екатеринбург (343)384-55-89	Магнитогорск (3519)55-03-13	Рязань (4912)46-61-64	Уфа (347)229-48-12
Иваново (4932)77-34-06	Москва (495)268-04-70	Самара (846)206-03-16	Челябинск (351)202-03-61
Ижевск (3412)26-03-58	Мурманск (8152)59-64-93	Санкт-Петербург (812)309-46-40	Череповец (8202)49-02-64
Казань (843)206-01-48	Набережные Челны (8552)20-53-41	Саратов (845)249-38-78	Ярославль (4852)69-52-93

сайт: www.ebmpapstnt-rt.ru || эл. почта: etm@nt-rt.ru